









































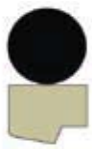







# Rod Seal Product Offering

Catalog EPS 5370/USA

## Profiles

Table 5-1: Product Profiles

Series	Description	Application (Duty)				Page	Series	Description	Application (Duty)				Page	
		Light	Medium	Heavy	Pneumatic				Light	Medium	Heavy	Pneumatic		
BD	 Premium O-ring Energized Lip Seal (available with optional back-up)					5-5	ON		PTFE Rod Cap Seal					5-28
BT	 Premium U-cup Rod Seal with Secondary Stabilizing Lip					5-7	CR		PTFE Rod Cap Seal to Retrofit O-ring Glands					5-32
BS	 U-cup Rod Seal with Secondary Stabilizing Lip					5-9	OC		Compact PTFE Rod Cap Seal					5-39
B3	 U-cup Rod Seal					5-11	BR		Premium Buffer Seal					5-45
UR	 Industrial U-cup Rod Seal					5-13	OD		PTFE Buffer Seal					5-48
E5	 Premium Rounded Lip U-cup Rod Seal					5-21	V6		Cushion Seal					5-54
TR	 Compact Seal with Anti-Extrusion Technology					5-24	OR		Rotary PTFE Cap Seal					5-57

5

09/01/07



# Rod Seal Decision Tree

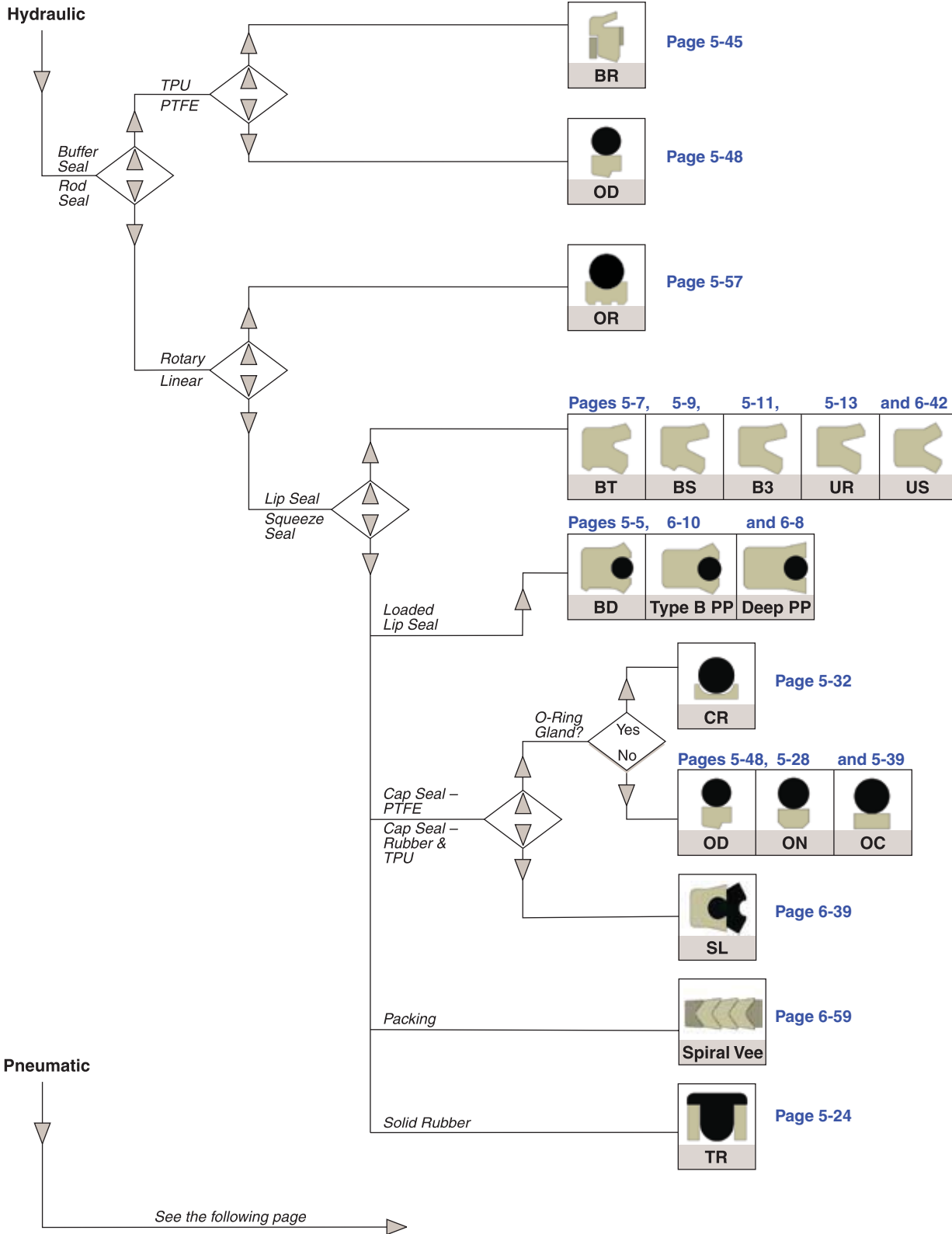

# Rod Seals

## Non-Symmetrical Rod Decision Tree (continued)

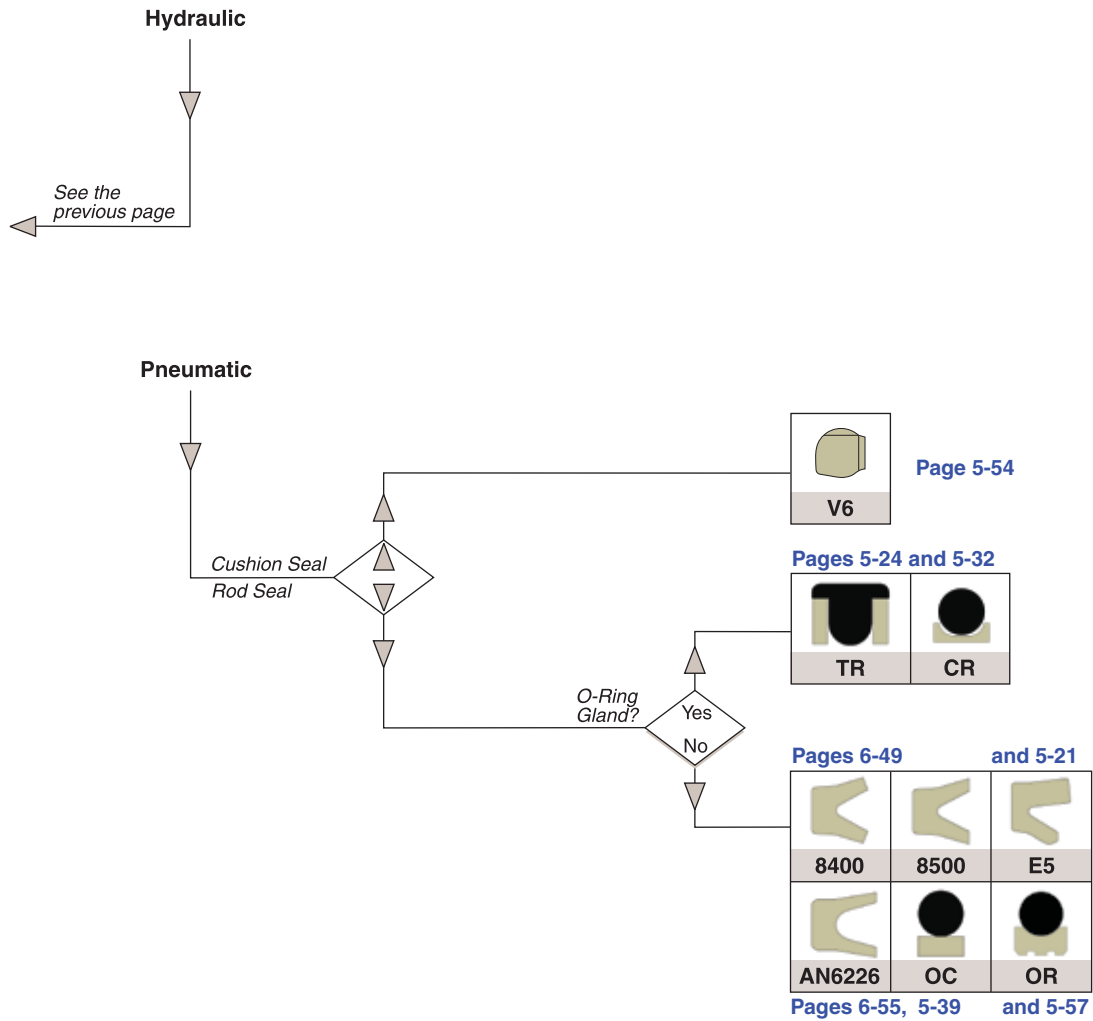

5

# Rod Seal BD Profile

Catalog EPS 5370/USA



## BD Profile, Premium O-ring Energized Lip Seal

The BD profile is a non-symmetrical profile rod seal. Its rectangular shaped cross section ensures stability in the gland. The o-ring energizer functions as a spring to maintain sealing contact under low pressure or vacuum applications. The knife trimmed, beveled lip does an excellent job wiping fluid film. A secondary sealing lip is located below the primary sealing lip, just above the base of the seal, to provide enhanced sealing performance and ensure a tight, stable fit in the gland. Available in Parker's proprietary urethanes, the BD profile provides long life, extrusion resistance, low compression set, shock load resistance and increased sealing performance at zero pressure. The BD profile is designed to be used as a stand alone rod seal or for use with the BR or OD profile buffer seals for more critical sealing applications. Also available with a positively-activated back-up.

5

### Technical Data

Standard Materials*	Temperature Range	Pressure Range†	Surface Speed
P4300A90	-65°F to 275°F (-54°C to 135°C)	5000 psi (344 bar)	< 1.6 ft/s (0.5 m/s)
P4301A90	-65°F to 275°F (-54°C to 135°C)	5000 psi (344 bar)	< 1.6 ft/s (0.5 m/s)
P4700A90	-65°F to 200°F (-54°C to 93°C)	5000 psi (344 bar)	< 1.6 ft/s (0.5 m/s)
P5065A88	-70°F to 200°F (-57°C to 93°C)	3500 psi (241 bar)	< 1.6 ft/s (0.5 m/s)

**\*Alternate Materials:** For applications that may require an alternate material, please contact your local Parker Seal representative.

**†Pressure Range** without wear rings (see Table 2-4, page 2-5).

**Pressure Range** with positively-activated back-up to 10,000 psi (688 bar).

**Options:** A back-up ring located in the heel of the BD profile can be provided for enhanced extrusion protection. See part number nomenclature for designating this option. Contact your local Parker Seal representative for price and availability.



BD Cross-Section

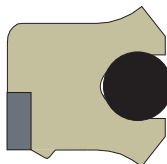

BD Cross-Section  
with Back-up

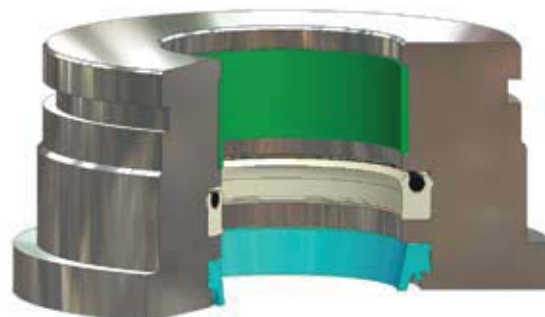

BD Installed in Rod Gland

09/01/07

## BD Profile

### Part Number Nomenclature — BD Profile

Table 5-2. BD Profile — Inch

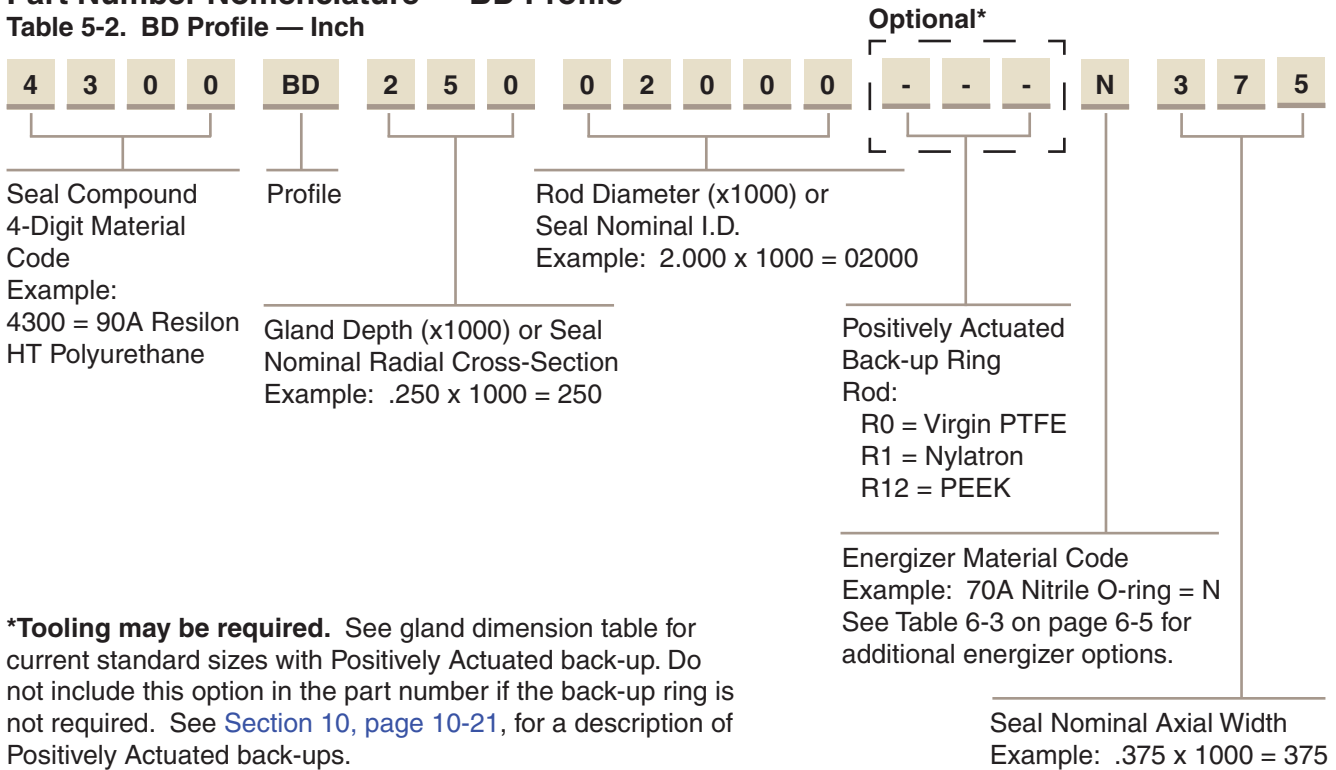

5

**\*Tooling may be required.** See gland dimension table for current standard sizes with Positively Actuated back-up. Do not include this option in the part number if the back-up ring is not required. See [Section 10, page 10-21](#), for a description of Positively Actuated back-ups.

### Part Number Nomenclature — BD Profile

Table 5-3. BD Profile — Metric

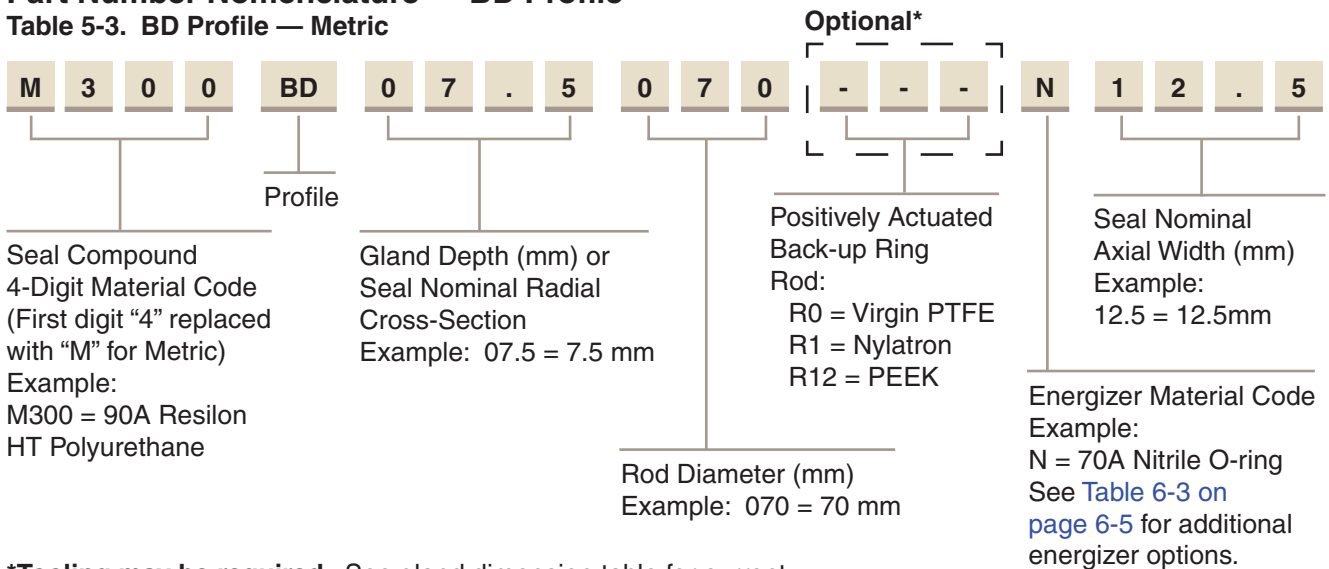

**\*Tooling may be required.** See gland dimension table for current standard sizes with Positively Actuated back-up. Do not include this option in the part number if the back-up ring is not required. See [Section 10, page 10-21](#), for a description of Positively Actuated back-ups.

### Gland Dimensions — BD Profile

BD gland dimensions are provided in [Tables 5-12 on page 5-15](#) and [5-13 on page 5-19](#).

02/15/08



# Rod Seal BT Profile

Catalog EPS 5370/USA



## BT Profile, Premium U-cup Rod Seal with Secondary Stabilizing Lip

The BT profile is a non-symmetrical design for use in hydraulic rod sealing applications. Using Finite Element Analysis, the BT profile was designed to provide improved sealing performance and stability in the gland. A knife trimming process is used to form the beveled lip which is best for removing fluid from the rod. By design, the BT profile has a more robust primary sealing lip than the BS profile and the secondary lip is located at the base of the heel. The standard compound for the BT profile is Parker's proprietary Resilon compound. The BT profile provides long life, extrusion resistance, low compression set, shock load resistance and increased sealing performance at zero pressure. The BT profile is designed for use as a stand alone rod seal or for use with the BR or OD profile buffer seals for more critical sealing applications.

5

### Technical Data

Standard Materials*	Temperature Range	Pressure Range†	Surface Speed
P4300A90	-65°F to 275°F (-54°C to 135°C)	5000 psi (344 bar)	< 1.6 ft/s (0.5 m/s)
P4301A90	-65°F to 275°F (-54°C to 135°C)	5000 psi (344 bar)	< 1.6 ft/s (0.5 m/s)

**\*Alternate Materials:** For applications that may require an alternate material, please contact your local Parker Seal representative.

**†Pressure Range** without wear rings (see Table 2-4, page 2-5).



*BT Cross-Section*

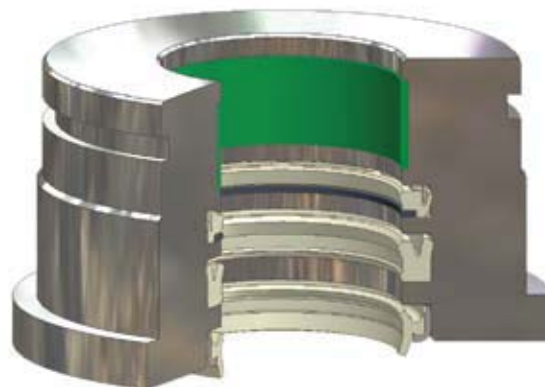

*BT Installed in Rod Gland*

09/01/07

## BT Profile

### Part Number Nomenclature — BT Profile

Table 5-4. BT Profile — Inch

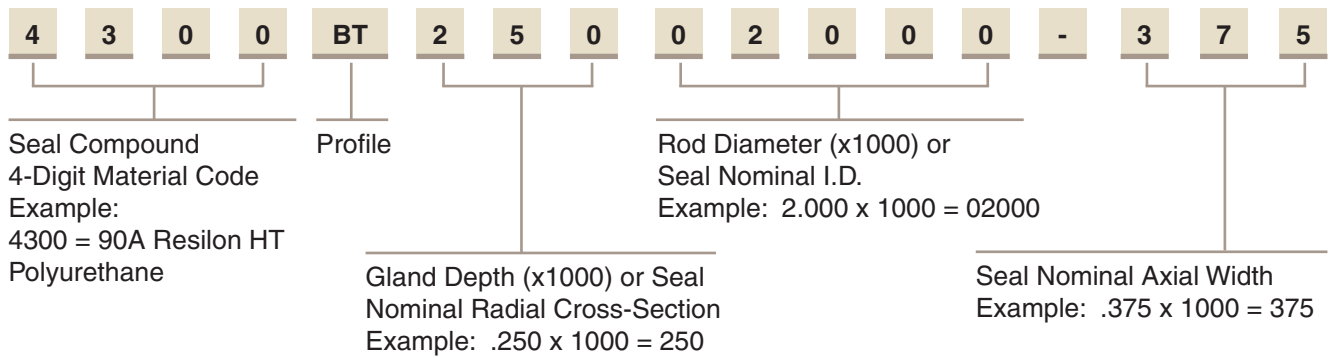

### Part Number Nomenclature — BT Profile

Table 5-5. BT Profile — Metric

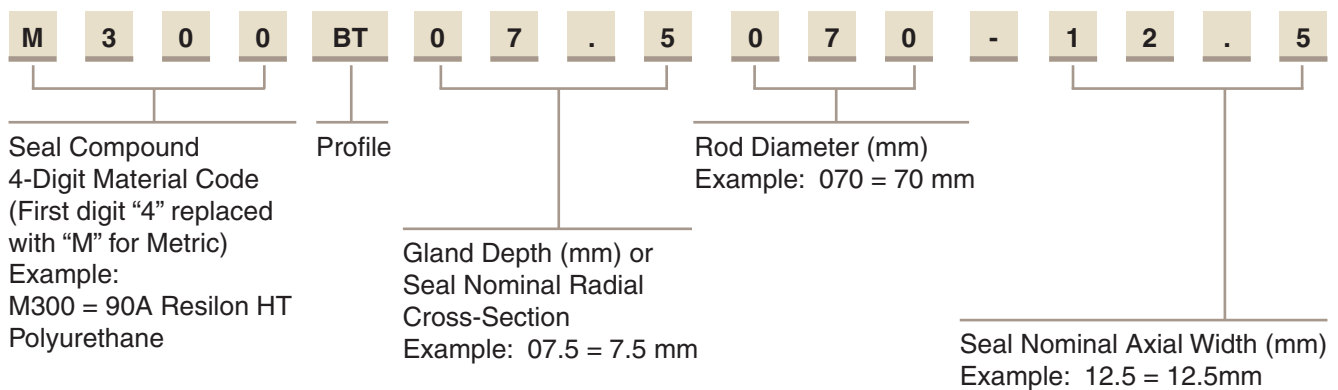

### Gland Dimensions — BT Profile

BT gland dimensions are provided in [Tables 5-12 on page 5-15](#) and [5-13 on page 5-19](#).

# Rod Seal BS Profile

Catalog EPS 5370/USA



## BS Profile, U-cup Rod Seal with Secondary Stabilizing Lip

The BS profile is a non-symmetrical profile designed for use in hydraulic rod sealing applications. A knife trimmed beveled sealing lip does an excellent job wiping fluid from the rod. In addition, a secondary sealing lip is located just above the base of the seal to provide enhanced sealing performance and ensure a tight, stable fit in the gland. Available in Parker proprietary urethanes, the BS profile provides long life, extrusion resistance, low compression set, shock load resistance and increased sealing performance at zero pressure. The BS profile is designed to be used as a stand alone rod seal or for use with the BR or OD profile buffer seals for more critical sealing applications.



*BS Cross-Section*

### Technical Data

Standard Materials*	Temperature Range	Pressure Range†	Surface Speed
P4300A90	-65°F to 275°F (-54°C to 135°C)	5000 psi (344 bar)	< 1.6 ft/s (0.5 m/s)
P4615A90	-65°F to 200°F (-54°C to 93°C)	5000 psi (344 bar)	< 1.6 ft/s (0.5 m/s)
P4700A90	-65°F to 200°F (-54°C to 93°C)	5000 psi (344 bar)	< 1.6 ft/s (0.5 m/s)
P5065A88	-70°F to 200°F (-57°C to 93°C)	3500 psi (241 bar)	< 1.6 ft/s (0.5 m/s)

\***Alternate Materials:** For applications that may require an alternate material, please contact your local Parker Seal representative.

†**Pressure Range** without wear rings (see Table 2-4, page 2-5).

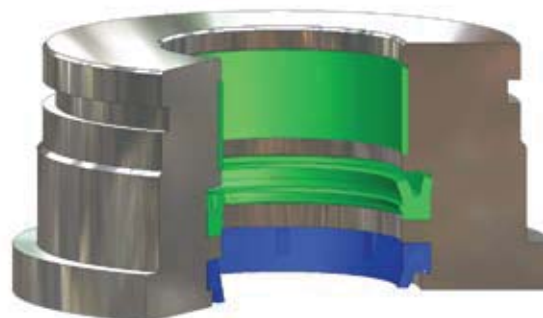

*BS Installed in Rod Gland*

5

09/01/07



## BS Profile

### Part Number Nomenclature — BS Profile

Table 5-6. BS Profile — Inch

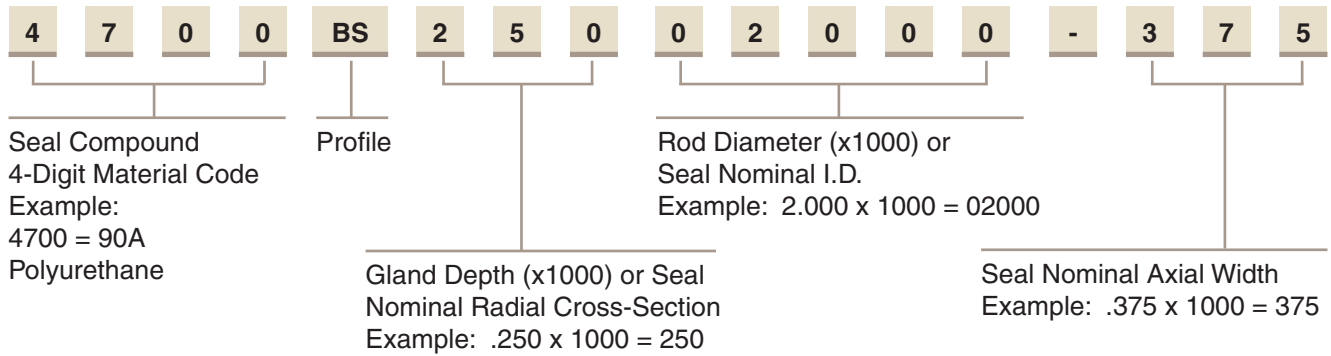

### Part Number Nomenclature — BS Profile

Table 5-7. BS Profile — Metric

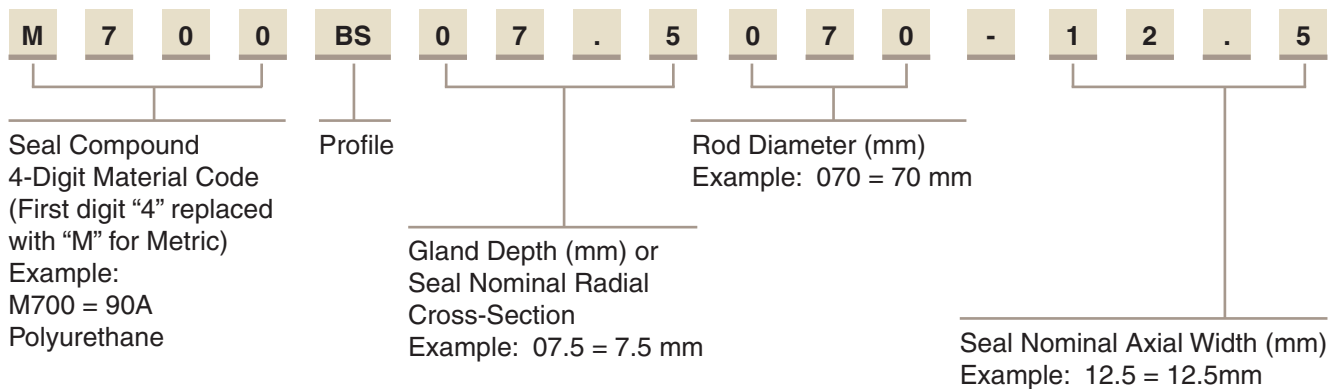

### Gland Dimensions — BS Profile

BS gland dimensions are provided in [Tables 5-12 on page 5-15](#) and [5-13 on page 5-19](#).

# Rod Seal B3 Profile

Catalog EPS 5370/USA



**B3 Cross-Section**

## B3 Profile, U-cup Rod Seal

The B3 profile is a non-symmetrical design for use in hydraulic rod sealing applications. The diameter of the B3 profile is designed to ensure a tight static side seal when installed. The knife trimmed, beveled lip does an excellent job wiping fluid film. The B3 profile is available in Parker proprietary compounds offering extrusion resistance, long wear, and low compression set. The B3 profile is designed for use as a stand alone rod seal and can be used with Parker's BR or OD profile buffer seals for more critical sealing applications. The B3 profile does not utilize a secondary sealing lip and can be used with a double lip wiper seal, such as the AY profile, to provide a multiple lip, rod sealing system without trapping pressure.

5

### Technical Data

Standard Materials*	Temperature Range	Pressure Range†	Surface Speed
P4300A90	-65°F to 275°F (-54°C to 135°C)	5000 psi (344 bar)	< 1.6 ft/s (0.5 m/s)
P4301A90	-65°F to 275°F (-54°C to 135°C)	5000 psi (344 bar)	< 1.6 ft/s (0.5 m/s)
P4700A90	-65°F to 200°F (-54°C to 93°C)	5000 psi (344 bar)	< 1.6 ft/s (0.5 m/s)
P5065A88	-70°F to 200°F (-57°C to 93°C)	3500 psi (241 bar)	< 1.6 ft/s (0.5 m/s)

**\*Alternate Materials:** For applications that may require an alternate material, please contact your local Parker Seal representative.

**†Pressure Range** without wear rings (see Table 2-4, page 2-5).

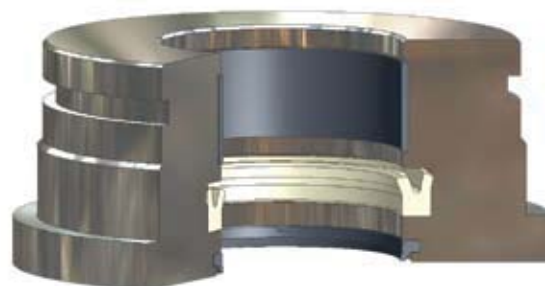

**B3 Installed in Rod Gland**

09/01/07

## B3 Profile

### Part Number Nomenclature — B3 Profile

Table 5-8. B3 Profile — Inch

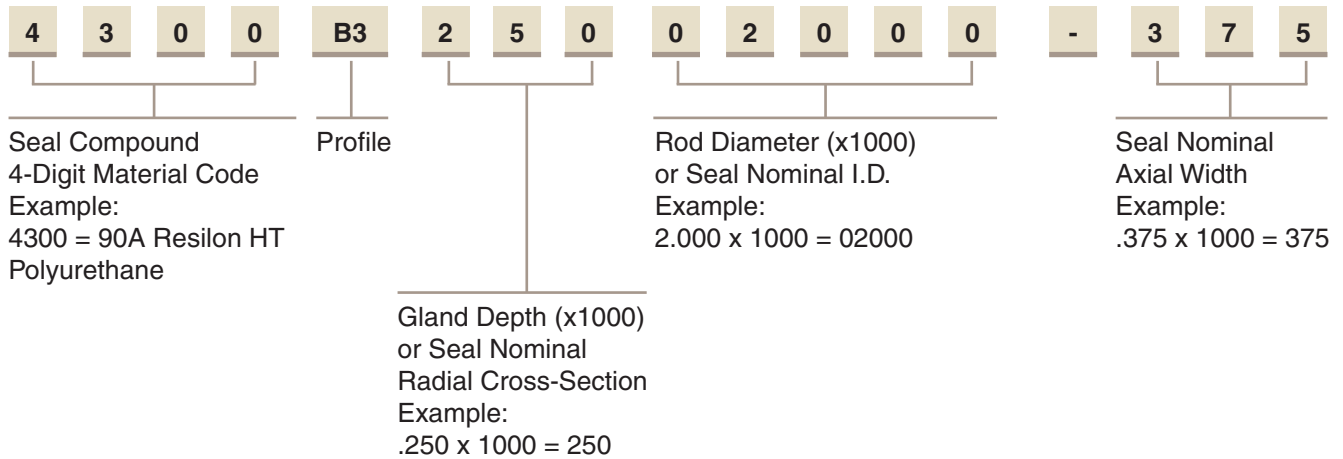

## 5

### Part Number Nomenclature — B3 Profile

Table 5-9. B3 Profile — Metric

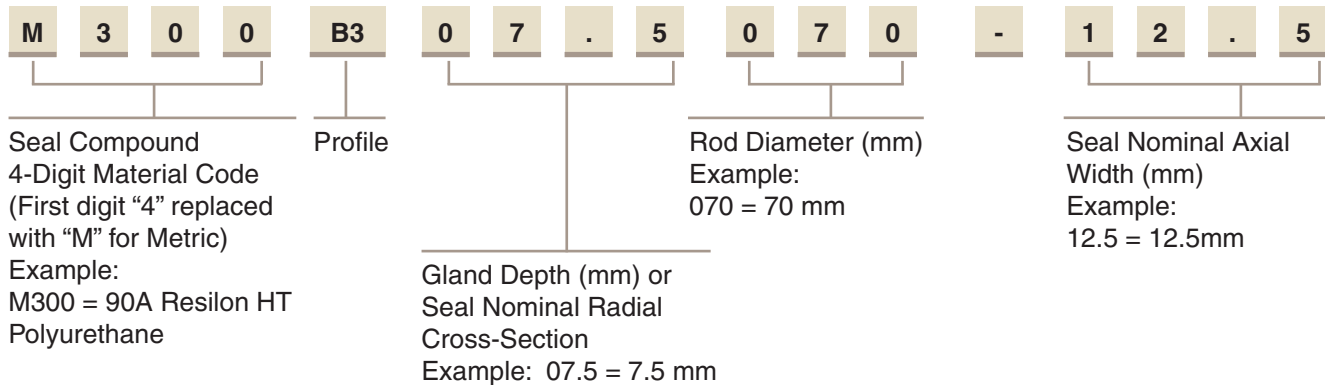

### Gland Dimensions — B3 Profile

B3 gland dimensions are provided in [Tables 5-12 on page 5-15](#) and [5-13 on page 5-19](#).

# Rod Seal UR Profile

Catalog EPS 5370/USA

## UR Profile, Industrial U-cup Rod Seal

The UR profile is a non-symmetrical, hydraulic cylinder rod seal. The knife trimmed, beveled lip faces the rod to provide enhanced low to high pressure sealing and wiping action. The UR profile is an economical choice, available in Parker's wear and extrusion resistant Molythane compound.



UR Cross-Section

### Technical Data

Standard Materials*	Temperature Range	Pressure Range†	Surface Speed
P4615A90	-65°F to 200°F (-54°C to 93°C)	5000 psi (344 bar)	< 1.6 ft/s (0.5 m/s)

\***Alternate Materials:** For applications that may require an alternate material, please contact your local Parker Seal representative.

†**Pressure Range** without wear rings (see Table 2-4, page 2-5).

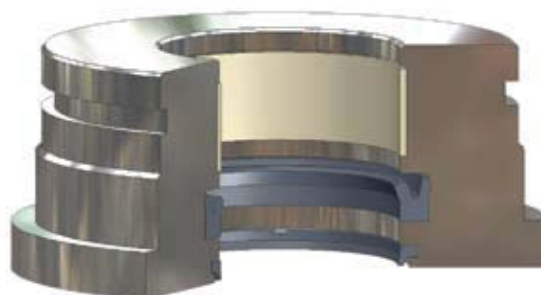

UR Installed in Rod Gland

5

09/01/07

## UR Profile

### Part Number Nomenclature — UR Profile

Table 5-10. UR Profile — Inch

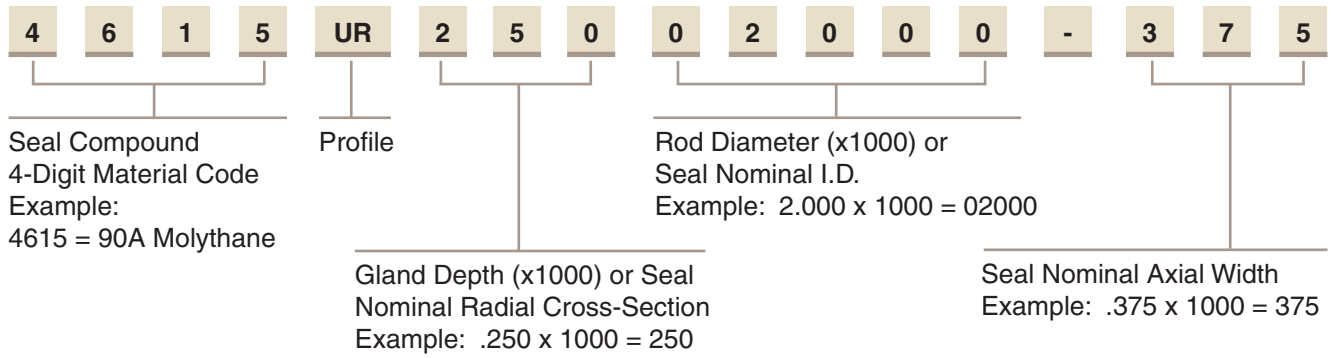

### Gland Dimensions — UR Profile

UR gland dimensions are provided in [Tables 5-12 on page 5-15](#) and [5-13 on page 5-19](#).

5

# Rod Seal

## BD, BT, BS, B3 and UR

### Gland Dimensions

Catalog EPS 5370/USA

#### Gland Dimensions — BD, BT, BS, B3 and UR Profiles — Inch

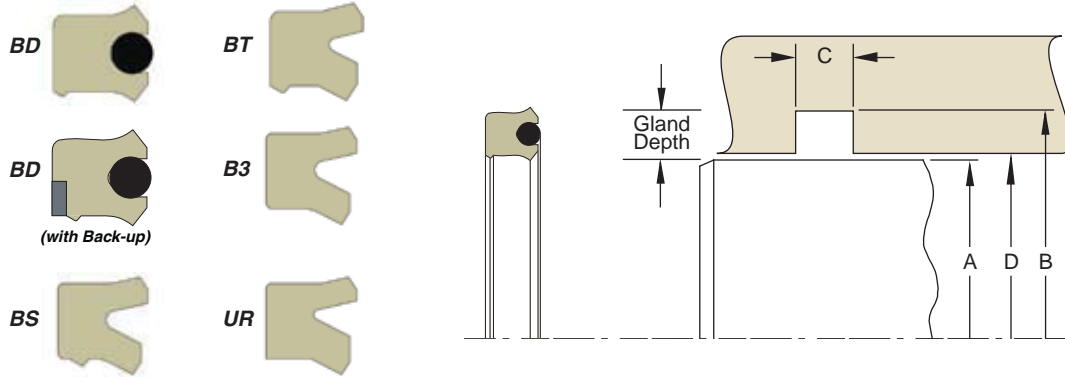

Table 5-11. Gland Dimension Tolerances

Nominal Gland Depth	A Rod Diameter	B Groove Diameter	C Groove Width	D Throat Diameter
1/8	+0.000/-0.001	+0.002/-0.000	+0.015/-0.000	+0.002/-0.000
3/16	+0.000/-0.002	+0.002/-0.000		+0.002/-0.000
1/4	+0.000/-0.002	+0.003/-0.000		+0.003/-0.000
5/16	+0.000/-0.002	+0.004/-0.000		+0.003/-0.000
3/8	+0.000/-0.002	+0.005/-0.000		+0.004/-0.000
7/16	+0.000/-0.003	+0.006/-0.000		+0.004/-0.000
1/2	+0.000/-0.003	+0.007/-0.000		+0.005/-0.000
5/8	+0.000/-0.003	+0.009/-0.000		+0.006/-0.000
3/4	+0.000/-0.004	+0.011/-0.000		+0.007/-0.000
1	+0.000/-0.005	+0.015/-0.000		+0.009/-0.000

Please refer to Engineering Section 2, Page 2-8 for surface finish and additional hardware considerations.

5

Table 5-12. BD, BT, BS, B3 and UR Gland Dimensions — Inch

A Rod Diameter	B Groove Diameter	C Groove Width	D Throat Diameter*	Compounds (X = Standard Offering)											Part Number					
				BD				BT		BS			B3		UR	Compound Code	Profile Code	Ener-gizer Code (BD)		
				4300	4700	5065	With Back-up	4300	4300	4700	4615	5065	4300	5065	4615					
0.219	0.469	0.248	0.220					X								XXXX	xx	12500219	-	225
0.250	0.500	0.206	0.251	X		X		X							X	XXXX	xx	12500250	-	187
0.312	0.562	0.206	0.313	X		X		X								XXXX	xx	12500312	-	187
0.375	0.625	0.206	0.376					X								XXXX	xx	12500375	-	187
0.437	0.687	0.138	0.438												X	XXXX	xx	12500437	-	125
0.437	0.687	0.206	0.438					X								XXXX	xx	12500437	-	187
0.500	0.687	0.172	0.501								X					XXXX	xx	09300500	-	156
0.500	0.750	0.206	0.501	X		X	X	X			X					XXXX	xx	12500500	-	187
0.500	0.750	0.275	0.501					X	X		X					XXXX	xx	12500500	-	250
0.500	1.000	0.413	0.501							X	X					XXXX	xx	25000500	-	375
0.562	0.812	0.275	0.563						X		X					XXXX	xx	12500562	-	250
0.625	0.875	0.275	0.626					X	X		X	X			X	XXXX	xx	12500625	-	250
0.625	1.000	0.303	0.626					X								XXXX	xx	18700625	-	275
0.625	1.000	0.343	0.626	X		X		X								XXXX	xx	18700625	-	312

\*If used with wear rings, refer to wear ring throat diameter, see Section 9. For custom groove calculations, see Appendix C.

09/01/07



**Table 5-12. BD, BT, BS, B3 and UR Gland Dimensions — Inch (Continued)**

A Rod Dia- meter	B Groove Dia- meter	C Groove Width	D Throat Dia- meter*	Compounds (X = Standard Offering)											Part Number								
				BD				BT	BS			B3		UR	Com- pound Code	Profile Code	Ener- gizer Code (BD)						
				4300	4700	5065	With Back-up	4300	4300	4700	4615	5065	4300	5065					4615				
0.687	1.062	0.206	0.626														X	XXXX	xx	18700687	-	187	
0.750	1.000	0.275	0.751	X		X			X	X		X	X					X	XXXX	xx	12500750	-	250
0.750	1.125	0.275	0.751						X										XXXX	xx	18700750	-	250
0.750	1.125	0.343	0.751															X	XXXX	xx	18700750	-	312
0.812	1.187	0.206	0.813															X	XXXX	xx	18700812	-	187
0.812	1.187	0.275	0.813						X										XXXX	xx	18700812	-	250
0.875	1.125	0.275	0.876						X		X		X					X	XXXX	xx	12500875	-	250
0.875	1.250	0.275	0.876								X	X	X						XXXX	xx	18700875	-	250
0.937	1.312	0.343	0.938								X		X						XXXX	xx	18700937	-	312
1.000	1.250	0.206	1.001						X	X	X	X	X						XXXX	xx	12501000	-	187
1.000	1.250	0.275	1.001	X	X	X	X	X	X	X	X	X	X					X	XXXX	xx	12501000	-	250
1.000	1.312	0.241	1.001						X										XXXX	xx	15601000	-	219
1.000	1.312	0.275	1.001								X	X	X						XXXX	xx	15601000	-	250
1.000	1.375	0.275	1.001								X	X	X					X	XXXX	xx	18701000	-	250
1.000	1.375	0.343	1.001	X		X	X	X	X	X	X	X	X					X	XXXX	xx	18701000	-	312
1.000	1.500	0.275	1.001															X	XXXX	xx	25001000	-	250
1.000	1.500	0.413	1.001						X		X							X	XXXX	xx	25001000	-	375
1.125	1.375	0.138	1.126														X	X	XXXX	xx	12501125	-	125
1.125	1.375	0.275	1.126						X				X						XXXX	xx	12501125	-	250
1.125	1.500	0.275	1.126						X									X	XXXX	xx	18701125	-	250
1.125	1.500	0.343	1.126	X		X	X	X	X		X	X	X					X	XXXX	xx	18701125	-	312
1.125	1.500	0.413	1.126	X		X													XXXX	xx	18701125	-	375
1.125	1.625	0.413	1.126						X										XXXX	xx	25001125	-	375
1.187	1.562	0.343	1.188															X	XXXX	xx	18701187	-	312
1.250	1.500	0.275	1.251						X	X			X					X	XXXX	xx	12501250	-	250
1.250	1.562	0.240	1.251						X										XXXX	xx	15601250	-	218
1.250	1.625	0.275	1.251															X	XXXX	xx	18701250	-	250
1.250	1.625	0.343	1.251	X	X	X	X	X	X	X	X	X	X					X	XXXX	xx	18701250	-	312
1.250	1.625	0.413	1.251								X		X						XXXX	xx	18701250	-	375
1.250	1.750	0.413	1.251						X		X		X					X	XXXX	xx	25001250	-	375
1.375	1.625	0.206	1.376								X	X	X						XXXX	xx	12501375	-	187
1.375	1.625	0.275	1.376								X		X	X				X	XXXX	xx	12501375	-	250
1.375	1.687	0.241	1.376						X										XXXX	xx	15601375	-	219
1.375	1.687	0.275	1.376								X	X	X						XXXX	xx	15601375	-	250
1.375	1.687	0.343	1.376						X	X									XXXX	xx	15601375	-	312
1.375	1.750	0.275	1.376						X									X	XXXX	xx	18701375	-	250
1.375	1.750	0.343	1.376	X	X	X			X		X	X	X					X	XXXX	xx	18701375	-	312
1.375	1.875	0.413	1.376						X	X			X					X	XXXX	xx	25001375	-	375
1.500	1.750	0.206	1.501	X		X			X	X	X	X							XXXX	xx	12501500	-	187
1.500	1.750	0.275	1.501						X										XXXX	xx	12501500	-	250
1.500	1.875	0.275	1.501						X									X	XXXX	xx	18701500	-	250
1.500	1.875	0.309	1.501								X		X						XXXX	xx	18701500	-	281
1.500	1.875	0.343	1.501									X						X	XXXX	xx	18701500	-	312
1.500	1.875	0.413	1.501	X	X	X	X	X	X		X		X					X	XXXX	xx	18701500	-	375
1.500	2.000	0.343	1.501															X	XXXX	xx	25001500	-	312
1.500	2.000	0.413	1.501	X		X	X	X	X	X	X	X	X					X	XXXX	xx	25001500	-	375
1.562	1.937	0.343	1.563						X				X						XXXX	xx	18701562	-	312
1.625	2.000	0.309	1.626								X								XXXX	xx	18701625	-	281

\*If used with wear rings, refer to wear ring throat diameter, see Section 9.  
For custom groove calculations, see Appendix C.



5

**Table 5-12. BD, BT, BS, B3 and UR Gland Dimensions — Inch (Continued)**

A Rod Diameter	B Groove Diameter	C Groove Width	D Throat Diameter*	Compounds (X = Standard Offering)											Part Number						
				BD				BT	BS				B3		UR	Compound Code	Profile Code		Ener-gizer Code (BD)		
				4300	4700	5065	With Back-up	4300	4300	4700	4615	5065	4300	5065	4615						
1.625	2.000	0.413	1.626	X		X	X	X	X	X						X	XXXX	xx	18701625	-	375
1.625	2.125	0.413	1.626						X							X	XXXX	xx	25001625	-	375
1.750	2.125	0.275	1.751					X									XXXX	xx	18701750	-	250
1.750	2.125	0.343	1.751					X			X						XXXX	xx	18701750	-	312
1.750	2.125	0.413	1.751	X	X	X	X	X	X	X	X	X			X		XXXX	xx	18701750	-	375
1.750	2.250	0.413	1.751	X	X	X	X	X	X	X	X	X			X		XXXX	xx	25001750	-	375
1.750	2.375	0.550	1.752					X									XXXX	xx	31201750	-	500
1.875	2.250	0.343	1.876						X			X					XXXX	xx	18701875	-	312
1.875	2.250	0.413	1.876	X		X	X	X	X		X	X					XXXX	xx	18701875	-	375
2.000	2.250	0.206	2.001							X	X	X					XXXX	xx	12502000	-	187
2.000	2.375	0.275	2.001					X									XXXX	xx	18702000	-	250
2.000	2.375	0.309	2.001							X		X					XXXX	xx	18702000	-	281
2.000	2.375	0.343	2.001					X			X		X	X	X		XXXX	xx	18702000	-	312
2.000	2.375	0.413	2.001	X	X	X	X	X	X	X	X	X			X		XXXX	xx	18702000	-	375
2.000	2.500	0.413	2.001	X	X	X	X	X	X	X	X	X			X		XXXX	xx	25002000	-	375
2.000	2.625	0.550	2.002						X		X						XXXX	xx	31202000	-	500
2.125	2.500	0.413	2.126								X						XXXX	xx	18702125	-	375
2.125	2.625	0.413	2.126					X		X		X					XXXX	xx	25002125	-	375
2.250	2.625	0.206	2.251										X	X			XXXX	xx	18702250	-	187
2.250	2.625	0.309	2.251												X		XXXX	xx	18702250	-	281
2.250	2.625	0.343	2.251					X									XXXX	xx	18702250	-	312
2.250	2.625	0.413	2.251	X		X	X		X	X	X	X					XXXX	xx	18702250	-	375
2.250	2.750	0.413	2.251	X	X	X	X	X	X	X	X	X			X		XXXX	xx	25002250	-	375
2.250	2.875	0.413	2.252							X		X					XXXX	xx	31202250	-	375
2.250	2.875	0.550	2.252							X		X	X	X	X		XXXX	xx	31202250	-	500
2.250	2.875	0.877	2.252					X									XXXX	xx	31202250	-	797
2.375	2.875	0.413	2.376					X									XXXX	xx	25002375	-	375
2.500	2.875	0.413	2.501	X	X	X	X	X	X		X				X		XXXX	xx	18702500	-	375
2.500	2.937	0.309	2.501					X									XXXX	xx	21802500	-	281
2.500	2.937	0.343	2.501					X									XXXX	xx	21802500	-	312
2.500	2.937	0.413	2.501					X									XXXX	xx	21802500	-	375
2.500	3.000	0.413	2.501	X	X	X	X	X	X	X	X	X			X		XXXX	xx	25002500	-	375
2.500	3.125	0.550	2.502						X	X	X	X	X	X	X		XXXX	xx	31202500	-	500
2.625	3.000	0.413	2.626						X		X						XXXX	xx	18702625	-	375
2.625	3.125	0.413	2.626	X		X		X	X		X	X					XXXX	xx	25002625	-	375
2.750	3.125	0.309	2.751							X		X	X	X			XXXX	xx	18702750	-	281
2.750	3.250	0.413	2.751	X	X	X	X	X		X	X	X			X		XXXX	xx	25002750	-	375
2.750	3.375	0.550	2.752						X	X	X	X	X	X			XXXX	xx	31202750	-	500
2.750	3.500	0.688	2.752						X	X	X	X					XXXX	xx	37502750	-	625
2.875	3.250	0.206	2.876										X	X			XXXX	xx	18702875	-	187
2.875	3.250	0.413	2.876					X									XXXX	xx	18702875	-	375
2.875	3.375	0.413	2.876	X		X											XXXX	xx	25002875	-	375
3.000	3.375	0.309	3.001							X		X					XXXX	xx	18703000	-	281
3.000	3.375	0.413	3.001					X									XXXX	xx	18703000	-	375
3.000	3.437	0.309	3.001					X									XXXX	xx	21803000	-	281
3.000	3.500	0.413	3.001	X	X	X	X	X	X	X	X	X			X		XXXX	xx	25003000	-	375
3.000	3.625	0.550	3.002						X			X			X		XXXX	xx	31203000	-	500
3.000	3.750	0.550	3.002						X			X					XXXX	xx	37503000	-	500

\*If used with wear rings, refer to wear ring throat diameter, see Section 9.  
 For custom groove calculations, see Appendix C.





**Table 5-12. BD, BT, BS, B3 and UR Gland Dimensions — Inch (Continued)**

A Rod Dia- meter	B Groove Dia- meter	C Groove Width	D Throat Dia- meter*	Compounds (X = Standard Offering)											Part Number					
				BD				BT	BS			B3		UR	Com- pound Code	Profile Code	Ener- gizer Code (BD)			
				4300	4700	5065	With Back-up	4300	4300	4700	4615	5065	4300	5065					4615	
3.000	3.750	0.688	3.002								X	X				XXXX	xx	37503000	-	625
3.250	3.625	0.413	3.251								X	X				XXXX	xx	18703250	-	375
3.250	3.750	0.413	3.251		X			X	X	X	X				X	XXXX	xx	25003250	-	375
3.500	3.875	0.309	3.501							X	X					XXXX	xx	18703500	-	281
3.500	3.875	0.413	3.501					X								XXXX	xx	18703500	-	375
3.500	4.000	0.343	3.501					X								XXXX	xx	25003500	-	312
3.500	4.000	0.413	3.501					X	X	X				X		XXXX	xx	25003500	-	375
3.500	4.125	0.550	3.502						X		X					XXXX	xx	31203500	-	500
3.500	4.250	0.550	3.502											X		XXXX	xx	37503500	-	500
3.500	4.250	0.688	3.502						X	X				X		XXXX	xx	37503500	-	625
3.750	4.250	0.413	3.751					X								XXXX	xx	25003750	-	375
3.750	4.375	0.550	3.752					X								XXXX	xx	31203750	-	500
3.875	4.250	0.343	3.876					X								XXXX	xx	18703785	-	312
3.875	4.750	0.825	3.877								X					XXXX	xx	43703875	-	750
4.000	4.375	0.413	4.001					X								XXXX	xx	18704000	-	375
4.000	4.500	0.343	4.001					X								XXXX	xx	25004000	-	312
4.000	4.500	0.413	4.001	X	X	X	X	X	X	X	X	X	X	X	X	XXXX	xx	25004000	-	375
4.000	4.500	0.618	4.001					X	X	X				X		XXXX	xx	25004000	-	562
4.000	4.625	0.413	4.002					X								XXXX	xx	31204000	-	375
4.000	4.750	0.688	4.002					X	X	X				X		XXXX	xx	37504000	-	625
4.250	4.625	0.309	4.251						X	X						XXXX	xx	18704250	-	281
4.250	4.750	0.413	4.251	X		X			X	X						XXXX	xx	25004250	-	375
4.250	4.750	0.618	4.251					X	X	X						XXXX	xx	25004250	-	562
4.250	5.000	0.688	4.252					X								XXXX	xx	37504250	-	625
4.250	5.000	0.784	4.252					X								XXXX	xx	37504250	-	713
4.500	5.000	0.343	4.501					X								XXXX	xx	25004500	-	312
4.500	5.000	0.413	4.501						X	X						XXXX	xx	25004500	-	375
4.500	5.125	0.413	4.502					X								XXXX	xx	31204500	-	375
4.500	5.125	0.550	4.502											X		XXXX	xx	31204500	-	500
4.500	5.250	0.688	4.502					X	X		X					XXXX	xx	37504500	-	625
4.625	5.250	0.688	4.627						X	X						XXXX	xx	31204625	-	625
4.750	5.375	0.550	4.752					X								XXXX	xx	31204750	-	500
4.750	5.625	0.825	4.752							X						XXXX	xx	43704750	-	750
5.000	5.375	0.309	5.001						X	X						XXXX	xx	18705000	-	281
5.000	5.375	0.413	5.001					X								XXXX	xx	18705000	-	375
5.000	5.500	0.413	5.001					X	X	X	X					XXXX	xx	25005000	-	375
5.000	5.500	0.618	5.001					X								XXXX	xx	25005000	-	562
5.000	5.500	0.792	5.001						X	X						XXXX	xx	25005000	-	720
5.000	5.562	0.378	5.001					X								XXXX	xx	28105000	-	344
5.000	5.562	0.550	5.001											X		XXXX	xx	28105000	-	500
5.000	5.750	0.550	5.002							X						XXXX	xx	37505000	-	500
5.000	5.750	0.688	5.002					X						X		XXXX	xx	37505000	-	625
5.250	6.000	0.688	5.252					X	X		X					XXXX	xx	37505250	-	625
5.500	6.125	0.413	5.502					X								XXXX	xx	31205500	-	375
5.500	6.250	0.688	5.502					X								XXXX	xx	37505500	-	625
5.750	6.250	0.413	5.751						X	X						XXXX	xx	25005750	-	375
6.000	6.500	0.618	6.001					X	X	X						XXXX	xx	25006000	-	562
6.000	6.500	0.792	6.001						X	X						XXXX	xx	25006000	-	720

\*If used with wear rings, refer to wear ring throat diameter, see Section 9.  
For custom groove calculations, see Appendix C.



**Table 5-12. BD, BT, BS, B3 and UR Gland Dimensions — Inch (Continued)**

A Rod Diameter	B Groove Diameter	C Groove Width	D Throat Diameter*	Compounds (X = Standard Offering)									Part Number								
				BD				BT	BS				B3		UR	Compound Code	Profile Code		Ener-gizer Code (BD)		
				4300	4700	5065	With Back-up	4300	4300	4700	4615	5065	4300	5065	4615						
6.000	6.750	0.688	6.002							X			X				XXXX	xx	37506000	-	625
6.500	7.000	0.413	6.501									X					XXXX	xx	25006500	-	375
6.500	7.500	0.688	6.502							X			X				XXXX	xx	50006500	-	625
6.750	7.375	0.550	6.752							X							XXXX	xx	31206750	-	500
6.750	7.500	0.688	6.752							X							XXXX	xx	37506750	-	625
7.000	7.500	0.618	7.001								X		X				XXXX	xx	25007000	-	562
7.000	8.000	0.825	7.002							X			X				XXXX	xx	50007000	-	750
7.500	8.250	0.688	7.502									X					XXXX	xx	37507500	-	625
7.500	8.500	0.688	7.502									X	X				XXXX	xx	50007500	-	625
8.000	8.750	0.688	8.002							X							XXXX	xx	37508000	-	625
8.500	9.000	0.413	8.501		X	X											XXXX	xx	25008500	-	375
8.500	9.250	0.688	8.502							X							XXXX	xx	37508500	-	625
8.500	9.500	0.688	8.502								X		X				XXXX	xx	50008500	-	625
9.000	9.500	0.413	9.001		X	X											XXXX	xx	25009000	-	375
9.000	10.000	0.825	9.002							X							XXXX	xx	50009000	-	750
9.500	10.250	0.688	9.502							X							XXXX	xx	37509500	-	625

\*If used with wear rings, refer to wear ring throat diameter, see Section 9.  
For custom groove calculations, see Appendix C.

NOTE: For sizes larger than those shown in the table, please contact your local Parker Seal representative.

**Gland Dimensions — BD, BT, BS, B3 and UR Profiles — Metric**

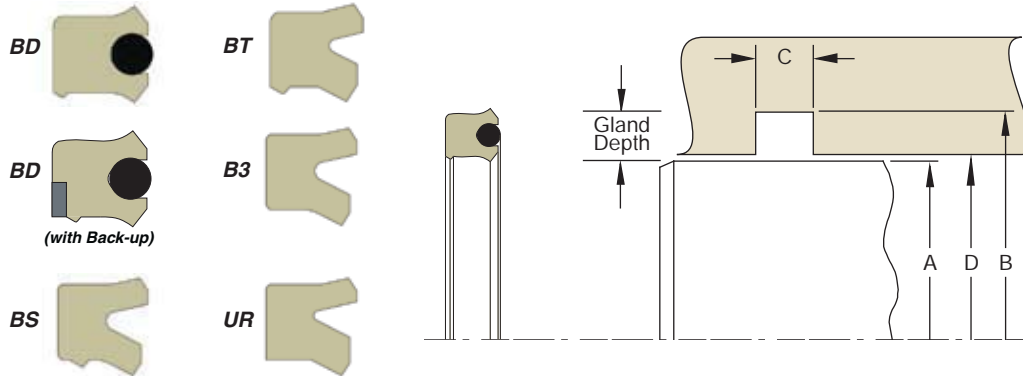

**Table 5-13. BD, BT, BS, B3 and UR Gland Dimensions — Metric**

A Rod Diameter	B Groove Diameter	C Groove Width	D Throat Diameter*	Compounds (X = Standard Offering)									Part Number									
				BD				BT	BS				B3		UR	Compound Code	Profile Code		Ener-gizer Code (BD)			
				M300	M700	M065	With Back-up	M300	M300	M700	M615	M065	M300	M065	M615							
f7	H9	+0.25/-0.00	H8																			
For ISO tolerances refer to Appendix F.																						
12.0	19.0	5.6	12.0							X								XXXX	xx	03.5012	-	5
12.0	20.0	7.0	12.0							X								XXXX	xx	04.0012	-	6
22.0	30.0	6.3	22.0												X	X		XXXX	xx	04.0022	-	5.7
25.0	31.0	5.6	25.0												X	X		XXXX	xx	03.0025	-	5
25.0	35.0	8.0	25.0							X								XXXX	xx	05.0025	-	7.3
28.0	38.0	8.0	28.0							X								XXXX	xx	05.0028	-	7.3

\*If used with wear rings, refer to wear ring throat diameter, see Section 9.  
For custom groove calculations, see Appendix C.



# Rod Seal

## E5 Profile

Catalog EPS 5370/USA



*E5 Cross-Section*

### E5 Profile, Premium Rounded Lip U-cup Rod Seal

Parker's E5 profile is a non-symmetrical rod seal designed to seal both lubricated and non-lubricated air. To ensure that critical surfaces retain lubrication, the radius edge of the lip is designed to hydroplane over pre-lubricated surfaces. The standard compound for the E5 profile is Parker's proprietary Nitroxile ELF compound N4274A85. This compound is formulated with proprietary internal lubricants to provide "Extreme Low Friction" and excellent wear resistance. This compound provides extended cycle life over standard nitrile and carboxylated nitrile compounds.

5

### Technical Data

Standard Materials*	Temperature Range	Pressure Range†	Surface Speed
N4274A85	-10°F to 250°F (-23°C to 121°C)	250 psi (17 bar)	< 3 ft/s (1 m/s)
N4180A80	-40°F to 250°F (-40°C to 121°C)	250 psi (17 bar)	< 3 ft/s (1 m/s)
V4208A90	-5°F to 400°F (-21°C to 204°C)	250 psi (17 bar)	< 3 ft/s (1 m/s)
P5065A88	-70°F to 200°F (-57°C to 93°C)	250 psi (17 bar)	< 3 ft/s (1 m/s)

**\*Alternate Materials:** For applications that may require an alternate material, please contact your local Parker Seal representative.

**†Pressure Range** without wear rings (see Table 2-4, page 2-5).

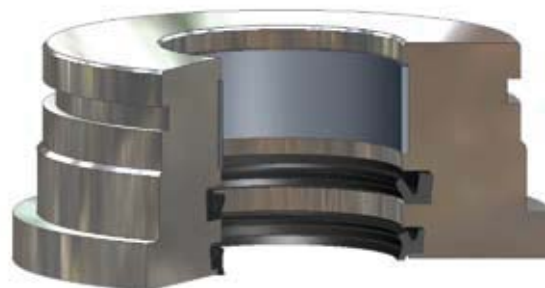

*E5 Installed in Rod Gland*

09/01/07

## E5 Profile

### Part Number Nomenclature — E5 Profile

Table 5-14. E5 Profile — Inch

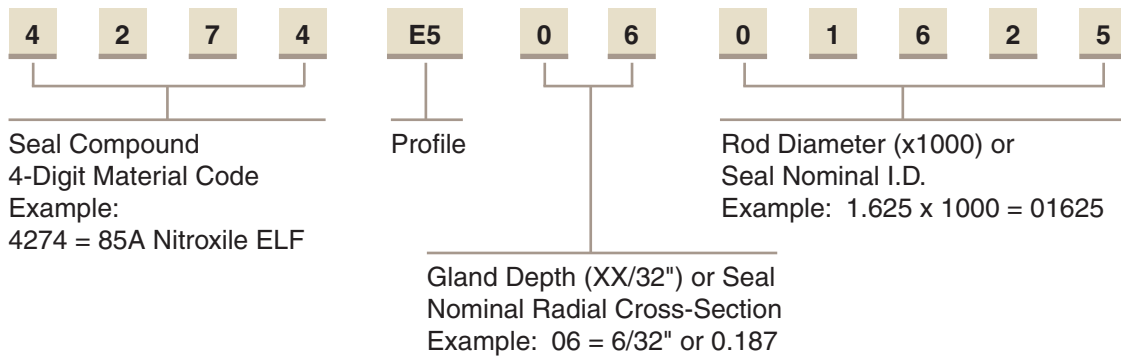

### Gland Dimensions — E5 Profile

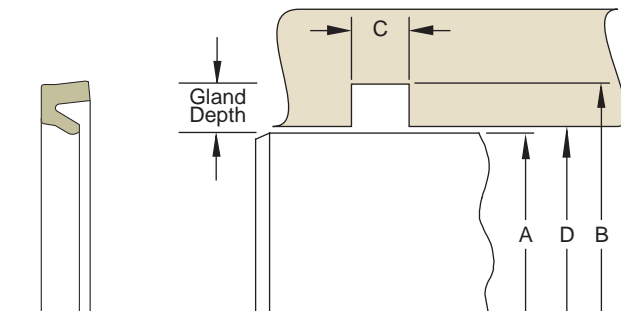

Table 5-15. Gland Dimension Tolerances

Nominal Gland Depth	A Rod Diameter	B Groove Diameter	C Groove Width	D Throat Diameter
1/8	+0.000/-0.001	+0.002/-0.000	+0.015/-0.000	+0.002/-0.000
3/16	+0.000/-0.002	+0.002/-0.000		+0.002/-0.000
1/4	+0.000/-0.002	+0.003/-0.000		+0.003/-0.000
5/16	+0.000/-0.002	+0.004/-0.000		+0.003/-0.000
3/8	+0.000/-0.002	+0.005/-0.000		+0.004/-0.000
7/16	+0.000/-0.003	+0.006/-0.000		+0.004/-0.000
1/2	+0.000/-0.003	+0.007/-0.000		+0.005/-0.000
5/8	+0.000/-0.003	+0.009/-0.000		+0.006/-0.000
3/4	+0.000/-0.004	+0.011/-0.000		+0.007/-0.000
1	+0.000/-0.005	+0.015/-0.000		+0.009/-0.000

Please refer to Engineering Section 2, Page 2-8 for surface finish and additional hardware considerations.

Table 5-16. E5 Gland Dimensions — Inch

A Rod Diameter	B Groove Diameter	C Groove Width	D Throat Diameter*	Compounds (X = Standard Offering)				Part Number	
				4180	4274	4208	5065	Compound Code	
0.125	0.375	0.156	0.126		X			XXXX	E50400125
0.187	0.375	0.125	0.188		X			XXXX	E50300187
0.250	0.500	0.156	0.251		X			XXXX	E50400250
0.375	0.625	0.156	0.376		X			XXXX	E50400375
0.500	0.750	0.156	0.501	X	X	X		XXXX	E50400500
0.625	0.875	0.156	0.626	X	X	X	X	XXXX	E50400625
0.750	1.000	0.156	0.751	X	X	X	X	XXXX	E50400750
0.875	1.125	0.156	0.876		X			XXXX	E50400875

\*If used with wear rings, refer to wear ring throat diameter, see Section 9.  
For custom groove calculations, see Appendix C.

**Table 5-16. E5 Gland Dimensions — Inch (Continued)**

A Rod Diameter	B Groove Diameter	C Groove Width	D Throat Diameter*	Compounds (X = Standard Offering)				Part Number	
				4180	4274	4208	5065	Compound Code	
1.000	1.250	0.156	1.001		X	X	X	XXXX	E50401000
1.000	1.312	0.188	1.001		X	X	X	XXXX	E50501000
1.250	1.500	0.156	1.251		X			XXXX	E50401250
1.250	1.562	0.188	1.251	X	X			XXXX	E50501250
1.375	1.687	0.188	1.376		X	X		XXXX	E50501375
1.375	1.750	0.218	1.377	X	X	X	X	XXXX	E50601375
1.500	1.875	0.218	1.502		X			XXXX	E50601500
1.750	2.125	0.218	1.752		X	X		XXXX	E50601750
2.000	2.375	0.218	2.002		X	X		XXXX	E50602000
2.500	2.875	0.218	2.502		X			XXXX	E50602500

\*If used with wear rings, refer to wear ring throat diameter, see Section 9.

For custom groove calculations, see Appendix C.

NOTE: For sizes larger than those shown in the table, please contact your local Parker Seal representative.

**Part Number Nomenclature — E5 Profile**

**Table 5-17. E5 Profile — Metric**

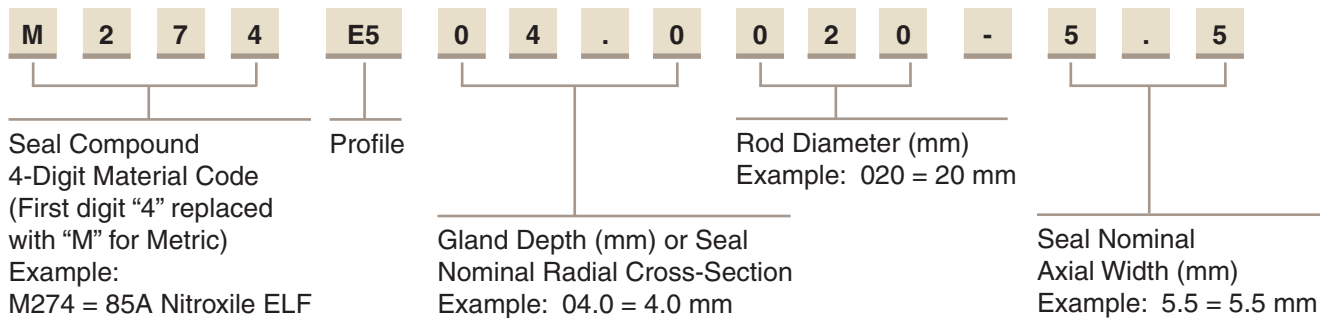

**Gland Dimensions — E5 Profile**

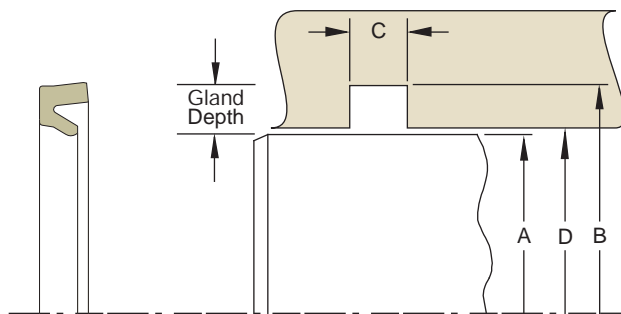

**Table 5-18. E5 Gland Dimensions — Metric (mm)**

A Rod Diameter	B Groove Diameter	C Groove Width	D Throat Diameter*	Compounds (X = Standard Offering)				Part Number	
				M180	M274	M208	M065	Compound Code	
f7	H9	+0.25/-0.00	H8						
For ISO tolerances refer to Appendix F.									
14.0	22.0	5.5	14.0	X				XXXX	E504.0014-5
20.0	28.0	6.0	20.0		X			XXXX	E504.0020-5.5
25.0	35.0	7.5	25.0		X			XXXX	E505.0025-7
30.0	38.0	5.0	30.0		X			XXXX	E504.0030-4.3
50.0	60.0	10.5	50.0		X	X		XXXX	E505.0050-9.5

\*If used with wear rings, refer to wear ring throat diameter, see Section 9.

For custom groove calculations, see Appendix C.

NOTE: For sizes larger than those shown in the table, please contact your local Parker Seal representative.

09/01/07

# Rod Seal TR Profile

Catalog EPS 5370/USA

5



## TR Profile (Rod T-seal) Compact Seal with Anti-Extrusion Technology

Parker's rod T-seal is designed to retrofit o-rings in no back-up, single back-up and two back-up standard industrial reciprocating glands. Its compact design provides improved stability and extrusion resistance in dynamic fluid sealing applications. The flange or base of the T-seal forms a tight seal in the gland and supports the anti-extrusion back-up rings. When energized, the back-up rings bridge the extrusion gap to protect the rubber sealing element from extrusion and system contamination. The rod T-seal eliminates the spiral or twisting failure that can occur when o-rings are used against a dynamic surface. Parker offers the rod T-seal in a variety of elastomer and back-up ring compounds to cover a wide range of fluid compatibility, pressure and temperature requirements.

Profile **TR0** for **no** back-up o-ring gland (standard offering)  
 Profile **TRS** for **single** back-up o-ring gland  
 Profile **TRT** for **two** back-up o-ring gland

The TR profile is sold only as an assembly (elastomer and back-ups).

## Technical Data

### Standard Materials



TR Cross-Section

Base Elastomer*	Temperature Range	Surface Speed
N4115A75	-40°F to 225F (-40°C to 107°C)	< 1.6 ft/s (0.5 m/s)
N4274A85	-10°F to 250°F (-23°C to 121°C)	< 1.6 ft/s (0.5 m/s)
V4205A75	-20°F to 400°F (-29°C to 204°C)	< 1.6 ft/s (0.5 m/s)
E4259A80	-65°F to 300°F (-54°C to 149°C)	< 1.6 ft/s (0.5 m/s)

**\*Alternate Materials:** For applications that may require an alternate material, please contact your local Parker Seal representative.

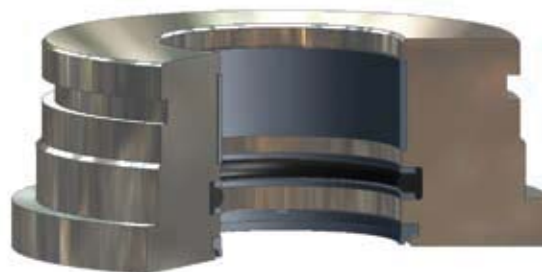

TR Installed in Rod Gland

09/01/07

### Technical Data (Continued)

#### Standard Materials

#### Back-up Rings\*\*

	Temperature Range	Pressure Range†
B001 (Nylatron)	-65°F to 250°F (-54°C to 121°C)	5,000 psi (344 bar)
B011 (Virgin PTFE)	-20°F to 250°F (-29°C to 121°C)	3,000 psi (206 bar)
B085 (PEEK)	-65°F to 500°F (-54°C to 260°C)	10,000 psi (689 bar)

\*\*Alternate Materials: For applications that may require an alternate material, please see Section 3 for alternate materials.

†Pressure Range without wear rings (see Table 2-4, page 2-5).

### Part Number Nomenclature — TR Profile

Table 5-19. TR Profile — Inch

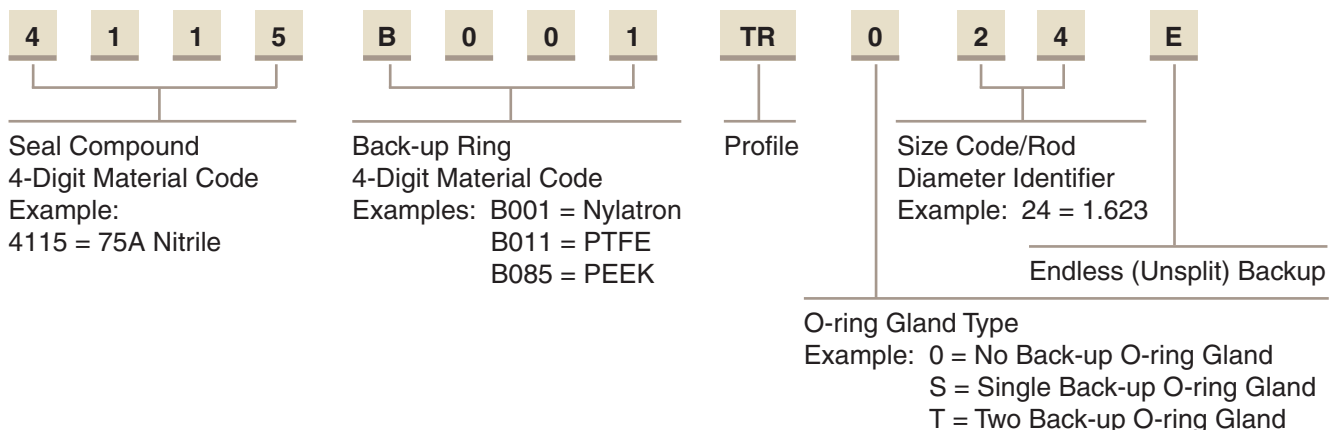

### Gland Dimensions — TR Profile

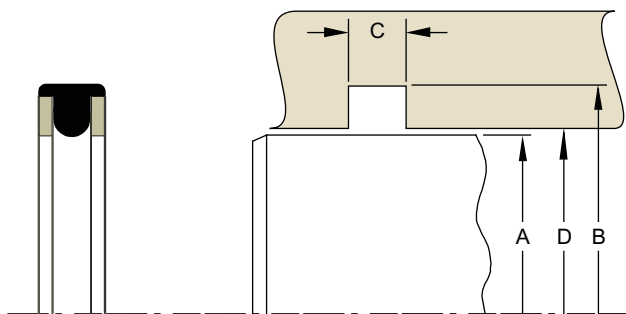

Please refer to Engineering Section 2, Page 2-8 for surface finish and additional hardware considerations.

Table 5-20. TR Gland Dimensions — Inch

A Rod Diameter	B Groove Diameter	C			D Throat Diameter*	Ref O-ring Dash Number	Compounds (X = Standard Offering)				Part Number				
		TR0 Groove Width	TRS Groove Width	TRT Groove Width			4115	4274	4205	4259	Com- pound Code	Back-up Ring Code	Groove Width Code**	Size Code	
+0.00/ -0.02	+0.002/ -0.000	+0.005/ -0.000	+0.005/ -0.000	+0.005/ -0.000	+0.001/ -0.000										
0.186	0.362	0.140	0.171	0.238	0.188	106	X		X		XXXX	B0XX	TR0	01	
0.249	0.425	0.140	0.171	0.238	0.251	108	X		X		XXXX	B0XX	TR0	02	
0.311	0.487	0.140	0.171	0.238	0.313	109	X		X		XXXX	B0XX	TR0	03	
0.373	0.615	0.187	0.208	0.275	0.376	204	X	X	X		XXXX	B0XX	TR0	04	

\* If used with wear rings, refer to wear ring throat diameter, see Section 9.

\*\*Chart reflects availability for TR0 only. For availability of TRS and TRT, please contact your local Parker Seal representative.

For custom groove calculations, see Appendix C.



**Table 5-20. TR Gland Dimensions — Inch\*\* (Continued)**

A Rod Diameter	B Groove Diameter	C			D Throat Diameter*	Ref O-ring Dash Number	Compounds (X = Standard Offering)				Part Number							
		TR0 Groove Width	TRS Groove Width	TRT Groove Width			4115	4274	4205	4259	Com- pound Code	Back-up Ring Code	Groove Width Code**	Size Code				
+0.000/ -0.002	+0.002/ -0.000	+0.005/ -0.000	+0.005/ -0.000	+0.005/ -0.000	+0.001/ -0.000													
0.435	0.677	0.187	0.208	0.275	0.438	205	X		X			XXXX	BOXX	TR0		05		
0.498	0.740	0.187	0.208	0.275	0.501	206	X	X	X			XXXX	BOXX	TR0		06		
0.560	0.802	0.187	0.208	0.275	0.563	207	X		X			XXXX	BOXX	TR0		07		
0.623	0.865	0.187	0.208	0.275	0.626	208	X	X	X	X		XXXX	BOXX	TR0		08		
0.685	0.927	0.187	0.208	0.275	0.688	209	X					XXXX	BOXX	TR0		09		
0.748	0.990	0.187	0.208	0.275	0.751	210	X	X	X	X		XXXX	BOXX	TR0		10		
0.810	1.052	0.187	0.208	0.275	0.813	211	X		X			XXXX	BOXX	TR0		11		
0.873	1.065	0.187	0.208	0.275	0.876	212	X		X			XXXX	BOXX	TR0		12		
0.935	1.177	0.187	0.208	0.275	0.938	213	X		X			XXXX	BOXX	TR0		13		
0.998	1.240	0.187	0.208	0.275	1.001	214	X	X	X			XXXX	BOXX	TR0		14		
1.060	1.302	0.187	0.208	0.275	1.063	215	X					XXXX	BOXX	TR0		15		
1.123	1.365	0.187	0.208	0.275	1.126	216	X		X	X		XXXX	BOXX	TR0		16		
1.185	1.427	0.187	0.208	0.275	1.188	217	X		X			XXXX	BOXX	TR0		17		
1.248	1.490	0.187	0.208	0.275	1.251	218	X	X	X	X		XXXX	BOXX	TR0		18		
1.310	1.552	0.187	0.208	0.275	1.313	219	X					XXXX	BOXX	TR0		19		
1.373	1.615	0.187	0.208	0.275	1.376	220	X		X	X		XXXX	BOXX	TR0		20		
1.435	1.677	0.187	0.208	0.275	1.438	221	X	X				XXXX	BOXX	TR0		21		
1.498	1.740	0.187	0.208	0.275	1.501	222	X	X	X	X		XXXX	BOXX	TR0		22		
1.498	1.868	0.281	0.311	0.410	1.501	325	X		X			XXXX	BOXX	TR0		23		
1.623	1.993	0.281	0.311	0.410	1.626	326	X	X				XXXX	BOXX	TR0		24		
1.748	2.118	0.281	0.311	0.410	1.751	327	X	X	X			XXXX	BOXX	TR0		25		
1.873	2.243	0.281	0.311	0.410	1.876	328	X	X				XXXX	BOXX	TR0		26		
1.998	2.368	0.281	0.311	0.410	2.001	329	X		X	X		XXXX	BOXX	TR0		27		
2.123	2.493	0.281	0.311	0.410	2.126	330	X		X			XXXX	BOXX	TR0		28		
2.248	2.618	0.281	0.311	0.410	2.251	331	X	X				XXXX	BOXX	TR0		29		
2.373	2.743	0.281	0.311	0.410	2.376	332	X		X			XXXX	BOXX	TR0		30		
2.498	2.868	0.281	0.311	0.410	2.501	333	X	X	X			XXXX	BOXX	TR0		31		
2.623	2.993	0.281	0.311	0.410	2.626	334	X		X			XXXX	BOXX	TR0		32		
2.748	3.118	0.281	0.311	0.410	2.751	335	X	X	X			XXXX	BOXX	TR0		33		
2.873	3.243	0.281	0.311	0.410	2.876	336	X					XXXX	BOXX	TR0		34		
2.998	3.368	0.281	0.311	0.410	3.001	337	X					XXXX	BOXX	TR0		35		
3.123	3.493	0.281	0.311	0.410	3.126	338	X					XXXX	BOXX	TR0		36		
3.248	3.618	0.281	0.311	0.410	3.251	339	X		X			XXXX	BOXX	TR0		37		
3.373	3.743	0.281	0.311	0.410	3.376	340	X		X			XXXX	BOXX	TR0		38		
3.498	3.868	0.281	0.311	0.410	3.501	341	X					XXXX	BOXX	TR0		39		
3.623	3.993	0.281	0.311	0.410	3.626	342	X					XXXX	BOXX	TR0		40		
3.748	4.118	0.281	0.311	0.410	3.751	343	X		X			XXXX	BOXX	TR0		41		
3.873	4.243	0.281	0.311	0.410	3.876	344	X					XXXX	BOXX	TR0		42		
3.998	4.368	0.281	0.311	0.410	4.001	345	X		X			XXXX	BOXX	TR0		43		
4.123	4.493	0.281	0.311	0.410	4.126	346	X					XXXX	BOXX	TR0		44		
4.248	4.618	0.281	0.311	0.410	4.251	347	X		X			XXXX	BOXX	TR0		45		
4.373	4.743	0.281	0.311	0.410	4.376	348	X					XXXX	BOXX	TR0		46		
4.498	4.868	0.281	0.311	0.410	4.501	349	X		X			XXXX	BOXX	TR0		47		
4.997	5.471	0.375	0.408	0.538	5.001	429	X		X	X		XXXX	BOXX	TR0		48		
5.247	5.721	0.375	0.408	0.538	5.251	431	X					XXXX	BOXX	TR0		49		
5.497	5.971	0.375	0.408	0.538	5.501	433	X					XXXX	BOXX	TR0		50		

\* If used with wear rings, refer to wear ring throat diameter, see Section 9.

\*\*Chart reflects availability for TR0 only. For availability of TRS and TRT, please contact your local Parker Seal representative. For custom groove calculations, see Appendix C.



Table 5-20. TR Gland Dimensions — Inch\*\* (Continued)

A Rod Diameter	B Groove Diameter	C			D Throat Diameter*	Ref O-ring Dash Number	Compounds (X = Standard Offering)				Part Number			
		TR0 Groove Width	TRS Groove Width	TRT Groove Width			4115	4274	4205	4259	Com- pound Code	Back-up Ring Code	Groove Width Code**	Size Code
+ .000/ - .002	+ .002/ - .000	+ .005/ - .000	+ .005/ - .000	+ .005/ - .000	+ .001/ - .000									
5.622	6.096	0.375	0.408	0.538	5.626	434	X				XXXX	B0XX	TR0	51
5.997	6.471	0.375	0.408	0.538	6.001	437	X				XXXX	B0XX	TR0	52
6.247	6.721	0.375	0.408	0.538	6.251	438	X				XXXX	B0XX	TR0	53
6.497	6.971	0.375	0.408	0.538	6.501	439	X		X		XXXX	B0XX	TR0	54
6.747	7.221	0.375	0.408	0.538	6.751	440	X				XXXX	B0XX	TR0	55
6.997	7.471	0.375	0.408	0.538	7.001	441	X				XXXX	B0XX	TR0	56
7.247	7.721	0.375	0.408	0.538	7.251	442	X				XXXX	B0XX	TR0	57
7.497	7.971	0.375	0.408	0.538	7.501	443	X		X		XXXX	B0XX	TR0	58
7.997	8.471	0.375	0.408	0.538	8.001	445	X				XXXX	B0XX	TR0	59
8.997	9.471	0.375	0.408	0.538	9.001	447	X				XXXX	B0XX	TR0	60
9.497	9.971	0.375	0.408	0.538	9.501	448	X				XXXX	B0XX	TR0	61
9.997	10.471	0.375	0.408	0.538	10.001	449	X				XXXX	B0XX	TR0	62
10.997	11.471	0.375	0.408	0.538	11.001	451	X				XXXX	B0XX	TR0	63
11.497	11.971	0.375	0.408	0.538	11.501	452					XXXX	B0XX	TR0	64
11.997	12.471	0.375	0.408	0.538	12.001	453	X				XXXX	B0XX	TR0	65

\* If used with wear rings, refer to wear ring throat diameter, [see Section 9](#).

\*\*Chart reflects availability for TR0 only. For availability of TRS and TRT, please contact your local Parker Seal representative. For custom groove calculations, [see Appendix C](#).

NOTE: For sizes larger than those shown in the table, please contact your local Parker Seal representative.

# Rod Seal ON Profile

Catalog EPS 5370/USA

5



ON Cross-Section

## ON Profile, PTFE Rod Cap Seal

The Parker ON profile is a bi-directional PTFE rod seal for use in low to medium duty hydraulic systems. The ON profile is a simple two piece design comprised of a standard size Parker o-ring energizing a wear resistant PTFE cap. The ON profile offers long wear and low friction, and because of its short assembly length, requires minimal space in the rod housing. The seal is commonly used in applications such as mobile hydraulics, machine tools, injection molding machines and hydraulic presses. Parker's ON profile will retrofit non-Parker seals of similar design.

The ON profile may be ordered without the energizer by omitting the energizer code. See part number nomenclature.

### Technical Data

Standard Materials* Cap		Temperature Range	Pressure Range†	Surface Speed
0401	40% bronze-filled PTFE	-200°F to 575°F (-129°C to 302°C)	5000 psi (344 bar)	< 13 ft/s (4 m/sec)
Energizer				
A	70A Nitrile	-30°F to 250°F (-34°C to 121°C)		

**\*Alternate Materials:** For applications that may require an alternate material, please see Section 3 for alternate PTFE (Table 3-4) and energizer (Table 3-5) materials.

**†Pressure Range** without wear rings (see Table 2-4, page 2-5).

### Options

**Notched side walls:** Notches can be added to the side walls of the PTFE cap. This can help to optimize the seal's response to fluid pressure. Notched side walls help ensure that fluid pressure fills the cavity between the side face of the seal and the side face of the seal gland. Consult your local Parker Seal representative for the availability and cost to add side notches to the ON profile.

N = Notched walls 

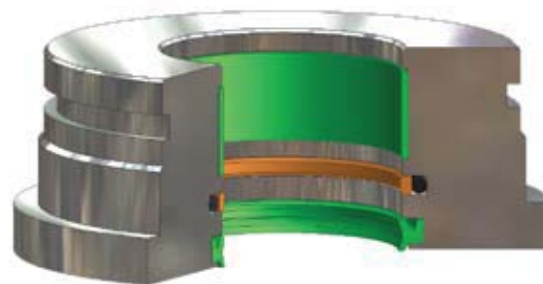

ON installed in Rod Gland

09/01/07

**Part Number Nomenclature — ON Profile**

**Table 5-21. ON Profile — Inch**

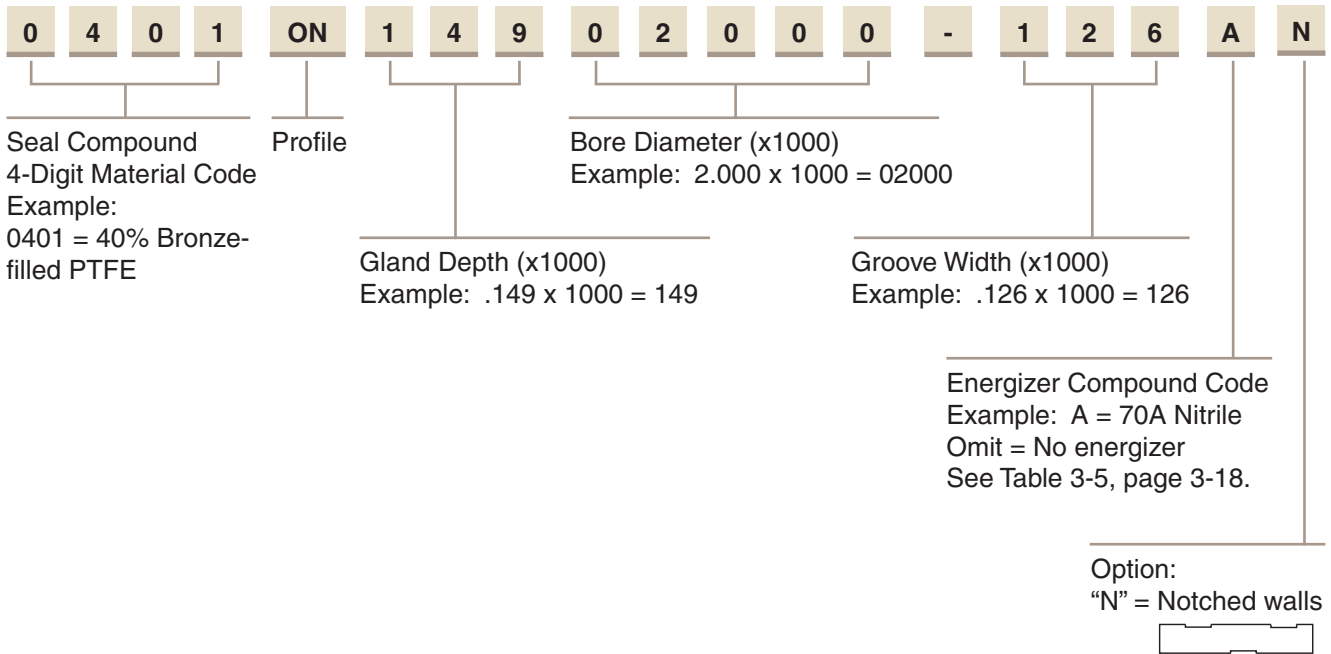

**Gland Dimensions — ON Profile**

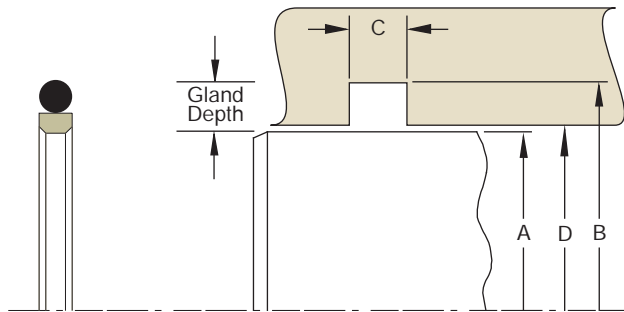

Please refer to Engineering Section 2, Page 2-8 for surface finish and additional hardware considerations.

**Table 5-23. ON Profile — Inch**

A Rod Diameter	B Groove Diameter	C Groove Width	D Throat Diameter*	O-ring Dash Number	Part Number
+ .000/- .001	+ .001/- .000	+ .005/- .000	+ .001/- .000		
0.500	0.674	0.081	0.501	015	0401ON08700500-081A
0.562	0.736	0.081	0.563	016	0401ON08700562-081A
0.625	0.799	0.081	0.626	017	0401ON08700625-081A
0.687	0.861	0.081	0.688	018	0401ON08700687-081A
0.750	0.924	0.081	0.751	019	0401ON08700750-081A
0.812	0.986	0.081	0.813	020	0401ON08700812-081A
0.875	1.049	0.081	0.876	021	0401ON08700875-081A
0.937	1.111	0.081	0.938	022	0401ON08700937-081A

\*If used with wear rings, refer to wear ring throat diameter, see Section 9. For custom groove calculations, see Appendix C.

## ON Profile

Table 5-23. ON Gland Dimensions — Inch

A Rod Diameter	B Groove Diameter	C Groove Width	D Throat Diameter*	O-ring Dash Number	Part Number
<b>+ .000/- .002</b>	<b>+ .002/- .000</b>	<b>+ .005/- .000</b>	<b>+ .002/- .000</b>		
1.000	1.298	0.126	1.001	122	0401ON14901000-126A
1.062	1.360	0.126	1.063	123	0401ON14901062-126A
1.125	1.423	0.126	1.126	124	0401ON14901125-126A
1.187	1.485	0.126	1.188	125	0401ON14901187-126A
1.250	1.548	0.126	1.251	126	0401ON14901250-126A
1.312	1.610	0.126	1.313	127	0401ON14901312-126A
1.375	1.673	0.126	1.376	128	0401ON14901375-126A
1.437	1.735	0.126	1.438	129	0401ON14901437-126A
1.500	1.798	0.126	1.501	130	0401ON14901500-126A
1.562	1.860	0.126	1.563	131	0401ON14901562-126A
1.625	1.923	0.126	1.626	132	0401ON14901625-126A
1.687	1.985	0.126	1.688	133	0401ON14901687-126A
1.750	2.048	0.126	1.751	134	0401ON14901750-126A
1.875	2.173	0.126	1.876	136	0401ON14901875-126A
<b>+ .000/- .003</b>	<b>+ .003/- .000</b>	<b>+ .005/- .000</b>	<b>+ .003/- .000</b>		
2.000	2.424	0.166	2.001	228	0401ON21202000-166A
2.125	2.549	0.166	2.126	228	0401ON21202125-166A
2.250	2.674	0.166	2.251	229	0401ON21202250-166A
2.375	2.799	0.166	2.376	230	0401ON21202375-166A
2.500	2.924	0.166	2.501	231	0401ON21202500-166A
2.625	3.049	0.166	2.626	232	0401ON21202625-166A
2.750	3.174	0.166	2.751	233	0401ON21202750-166A
2.875	3.299	0.166	2.876	234	0401ON21202875-166A
3.000	3.424	0.166	3.001	235	0401ON21203000-166A
3.125	3.549	0.166	3.126	236	0401ON21203125-166A
3.250	3.674	0.166	3.251	237	0401ON21203250-166A
3.375	3.799	0.166	3.376	238	0401ON21203375-166A
3.500	3.924	0.166	3.501	239	0401ON21203500-166A
3.625	4.049	0.166	3.626	240	0401ON21203625-166A
3.750	4.174	0.166	3.751	241	0401ON21203750-166A
3.875	4.299	0.166	3.876	242	0401ON21203875-166A
<b>+ .000/- .004</b>	<b>+ .004/- .000</b>	<b>+ .005/- .000</b>	<b>+ .004/- .000</b>		
4.000	4.616	0.247	4.002	347	0401ON30804000-247A
4.125	4.741	0.247	4.127	348	0401ON30804125-247A
4.250	4.866	0.247	4.252	349	0401ON30804250-247A
4.375	4.991	0.247	4.377	350	0401ON30804375-247A
4.500	5.116	0.247	4.502	351	0401ON30804500-247A
4.625	5.241	0.247	4.627	352	0401ON30804625-247A
4.750	5.366	0.247	4.752	353	0401ON30804750-247A
4.875	5.491	0.247	4.877	354	0401ON30804875-247A
5.000	5.616	0.247	5.002	355	0401ON30805000-247A
5.125	5.741	0.247	5.127	356	0401ON30805125-247A
5.250	5.866	0.247	5.252	357	0401ON30805250-247A
5.375	5.991	0.247	5.377	358	0401ON30805375-247A
5.500	6.116	0.247	5.502	359	0401ON30805500-247A
5.625	6.241	0.247	5.627	360	0401ON30805625-247A
5.750	6.366	0.247	5.752	361	0401ON30805750-247A
5.875	6.491	0.247	5.877	361	0401ON30805875-247A

\*If used with wear rings, refer to wear ring throat diameter, see Section 9.

For custom groove calculations, see Appendix C.

09/01/07



Table 5-23. ON Gland Dimensions — Inch (Continued)

A Rod Diameter	B Groove Diameter	C Groove Width	D Throat Diameter*	O-ring Dash Number	Part Number
<b>+ .000/- .004</b>	<b>+ .004/- .000</b>	<b>+ .005/- .000</b>	<b>+ .004/- .000</b>		
6.000	6.616	0.247	6.002	362	0401ON30806000-247A
6.125	6.741	0.247	6.127	362	0401ON30806125-247A
6.250	6.866	0.247	6.252	363	0401ON30806250-247A
6.375	6.991	0.247	6.377	363	0401ON30806375-247A
6.500	7.116	0.247	6.502	364	0401ON30806500-247A
6.750	7.366	0.247	6.752	365	0401ON30806750-247A
7.000	7.616	0.247	7.002	366	0401ON30807000-247A
7.250	7.866	0.247	7.252	367	0401ON30807250-247A
7.500	8.116	0.247	7.502	368	0401ON30807500-247A
7.750	8.366	0.247	7.752	369	0401ON30807750-247A
<b>+ .000/- .005</b>	<b>+ .005/- .000</b>	<b>+ .005/- .000</b>	<b>+ .005/- .000</b>		
8.000	8.830	0.320	8.002	445	0401ON41508000-320A
8.250	9.080	0.320	8.252	446	0401ON41508250-320A
8.500	9.330	0.320	8.502	446	0401ON41508500-320A
9.000	9.830	0.320	9.002	447	0401ON41509000-320A
9.500	10.330	0.320	9.502	448	0401ON41509500-320A
10.000	10.830	0.320	10.002	449	0401ON41510000-320A
10.500	11.330	0.320	10.502	450	0401ON41510500-320A
11.000	11.830	0.320	11.002	451	0401ON41511000-320A
11.500	12.330	0.320	11.502	452	0401ON41511500-320A
12.000	12.830	0.320	12.002	453	0401ON41512000-320A
12.500	13.330	0.320	12.502	454	0401ON41512500-320A
13.000	13.830	0.320	13.002	455	0401ON41513000-320A
13.500	14.330	0.320	13.502	456	0401ON41513500-320A
14.000	14.830	0.320	14.002	457	0401ON41514000-320A
14.500	15.330	0.320	14.502	458	0401ON41514500-320A
15.000	15.830	0.320	15.002	459	0401ON41515000-320A
15.500	16.330	0.320	15.502	460	0401ON41515500-320A
16.000	16.830	0.320	16.002	461	0401ON41516000-320A

\*If used with wear rings, refer to wear ring throat diameter, see Section 9.

For custom groove calculations, see Appendix C.

NOTE: For sizes larger than those shown in the table, please contact your local Parker Seal representative.

# Rod Seal CR Profile

Catalog EPS 5370/USA

5



## CR Profile, PTFE Rod Cap Seal to Retrofit O-ring Glands

The Parker CR profile is a cap seal with anti-extrusion, low friction and low wear features. The seal is a bi-directional rod seal for use in pneumatic and low to medium duty applications. Because of its short assembly length, it requires minimal space in the rod housing. The three CR profiles will fit into standard o-ring grooves without modification. Parker's CR profiles will retrofit non-Parker seals of similar design.

- CR0 fits a standard o-ring groove
- CR1 fits an o-ring groove designed for one back-up ring
- CR2 fits an o-ring groove designed for two back-up rings

The CR profile may be ordered without the energizer by omitting the energizer code. See part number nomenclature.



CR Cross-Section

### Technical Data

Standard Materials*	Temperature Range	Pressure Range†	Surface Speed
<b>Cap</b>			
0401 40% bronze filled PTFE	-200°F to 575°F (-129°C to 302°C)	5000 psi (344 bar)	< 13 ft/s (4 m/sec)
<b>Energizer</b>			
A 70A Nitrile	-30°F to 250°F (-34°C to 121°C)		

\***Alternate Materials:** For pneumatic applications, compound 0102 is recommended. For applications that may require an alternate material, please see Section 3 for alternate PTFE (Table 3-4) and energizer (Table 3-5) materials.

†**Pressure Range** without wear rings (see Table 2-4, page 2-5).

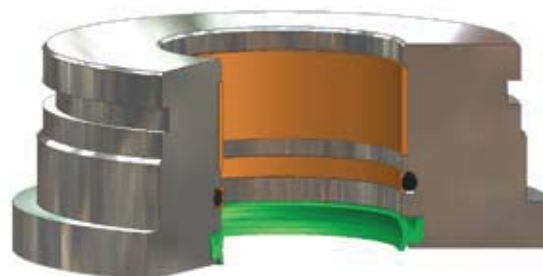

CR installed in Rod Gland

09/01/07

### Technical Data (Continued)

#### Options

**Notched side walls:** Notches can be added to the side walls of the PTFE cap. This can help to optimize the seal's response to fluid pressure. Notched side walls help ensure that fluid pressure fills the cavity between the side face of the seal and the side face of the seal gland. Consult your local Parker Seal representative for the availability and cost to add side notches to the CR profile.

N = Notched walls 

### Part Number Nomenclature — CR Profile

Table 5-24. CR Profile — Inch

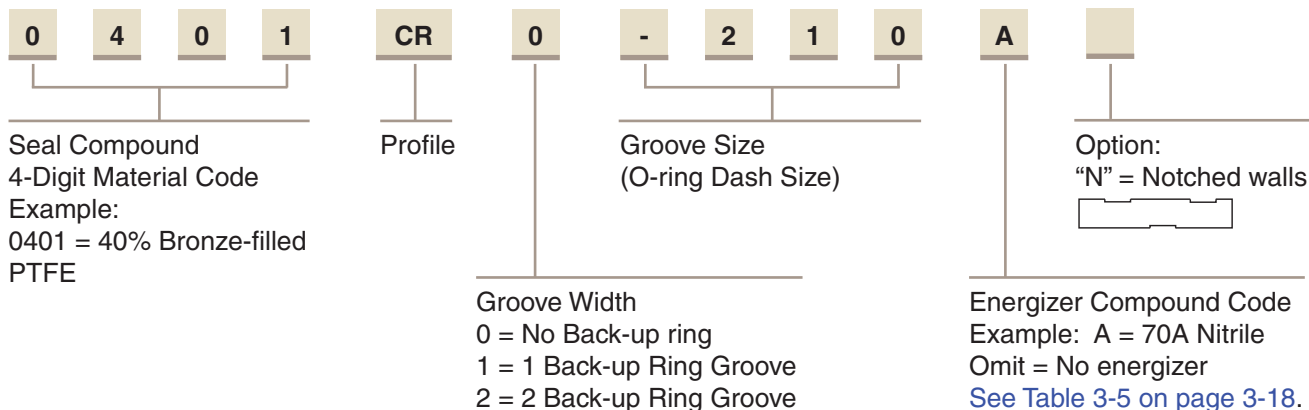

### Gland Dimensions — CR Profile

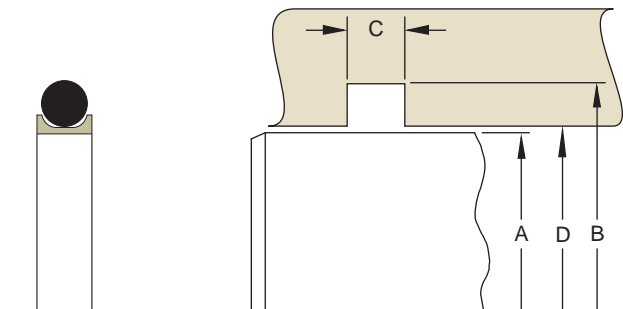

Please refer to Engineering Section 2, Page 2-8 for surface finish and additional hardware considerations.

Table 5-25. CR Profile — Inch

A Rod Diameter	B Groove Diameter	C Groove Width (CR0)	C Groove Width (CR1)	C Groove Width (CR2)	D Throat Diameter*	O-ring Dash Number	CR Part Number (X = Groove Width of 0, 1 or 2)
+0.000/-0.002	+0.002/-0.000	+0.005/-0.000	+0.005/-0.000	+0.005/-0.000	+0.001/-0.000		
0.125	0.235	0.093	0.138	0.205	0.126	006	0401CR X-006A
0.156	0.266	0.093	0.138	0.205	0.157	007	0401CR X-007A
0.187	0.297	0.093	0.138	0.205	0.188	008	0401CR X-008A
0.219	0.329	0.093	0.138	0.205	0.220	009	0401CR X-009A
0.250	0.360	0.093	0.138	0.205	0.251	010	0401CR X-010A
0.312	0.422	0.093	0.138	0.205	0.313	011	0401CR X-011A
0.375	0.485	0.093	0.138	0.205	0.376	012	0401CR X-012A

\*If used with wear rings, refer to wear ring throat diameter, see Section 9. For custom groove calculations, see Appendix C.



**CR Profile**

**Table 5-25. CR Gland Dimensions — Inch (Continued)**

A Rod Diameter	B Groove Diameter	C Groove Width (CR0)	C Groove Width (CR1)	C Groove Width (CR2)	D Throat Diameter*	O-ring Dash Number	CR Part Number (X = Groove Width of 0, 1 or 2)
<b>+0.000/-0.002</b>	<b>+0.002/-0.000</b>	<b>+0.005/-0.000</b>	<b>+0.005/-0.000</b>	<b>+0.005/-0.000</b>	<b>+0.001/-0.000</b>		
0.437	0.547	0.093	0.138	0.205	0.438	013	0401CR X-013A
0.500	0.610	0.093	0.138	0.205	0.501	014	0401CR X-014A
0.562	0.672	0.093	0.138	0.205	0.563	015	0401CR X-015A
0.625	0.735	0.093	0.138	0.205	0.626	016	0401CR X-016A
0.687	0.797	0.093	0.138	0.205	0.688	017	0401CR X-017A
0.750	0.860	0.093	0.138	0.205	0.751	018	0401CR X-018A
0.812	0.922	0.093	0.138	0.205	0.813	019	0401CR X-019A
0.875	0.985	0.093	0.138	0.205	0.876	020	0401CR X-020A
0.937	1.047	0.093	0.138	0.205	0.938	021	0401CR X-021A
1.000	1.110	0.093	0.138	0.205	1.001	022	0401CR X-022A
1.062	1.172	0.093	0.138	0.205	1.063	023	0401CR X-023A
1.125	1.235	0.093	0.138	0.205	1.126	024	0401CR X-024A
1.187	1.297	0.093	0.138	0.205	1.188	025	0401CR X-025A
1.250	1.360	0.093	0.138	0.205	1.251	026	0401CR X-026A
1.312	1.422	0.093	0.138	0.205	1.313	027	0401CR X-027A
1.375	1.485	0.093	0.138	0.205	1.376	028	0401CR X-028A
<b>+0.000/-0.002</b>	<b>+0.002/-0.000</b>	<b>+0.005/-0.000</b>	<b>+0.005/-0.000</b>	<b>+0.005/-0.000</b>	<b>+0.002/-0.000</b>		
0.125	0.301	0.140	0.171	0.238	0.126	104	0401CR X-104A
0.156	0.332	0.140	0.171	0.238	0.157	105	0401CR X-105A
0.187	0.363	0.140	0.171	0.238	0.188	106	0401CR X-106A
0.218	0.394	0.140	0.171	0.238	0.219	107	0401CR X-107A
0.250	0.426	0.140	0.171	0.238	0.251	108	0401CR X-108A
0.312	0.488	0.140	0.171	0.238	0.313	109	0401CR X-109A
0.375	0.551	0.140	0.171	0.238	0.376	110	0401CR X-110A
0.437	0.613	0.140	0.171	0.238	0.438	111	0401CR X-111A
0.500	0.676	0.140	0.171	0.238	0.501	112	0401CR X-112A
0.562	0.738	0.140	0.171	0.238	0.563	113	0401CR X-113A
0.625	0.801	0.140	0.171	0.238	0.626	114	0401CR X-114A
0.687	0.863	0.140	0.171	0.238	0.688	115	0401CR X-115A
0.750	0.926	0.140	0.171	0.238	0.751	116	0401CR X-116A
0.812	0.988	0.140	0.171	0.238	0.813	117	0401CR X-117A
0.875	1.051	0.140	0.171	0.238	0.876	118	0401CR X-118A
0.937	1.113	0.140	0.171	0.238	0.938	119	0401CR X-119A
1.000	1.176	0.140	0.171	0.238	1.001	120	0401CR X-120A
1.062	1.238	0.140	0.171	0.238	1.063	121	0401CR X-121A
1.125	1.301	0.140	0.171	0.238	1.126	122	0401CR X-122A
1.187	1.363	0.140	0.171	0.238	1.188	123	0401CR X-123A
1.250	1.426	0.140	0.171	0.238	1.251	124	0401CR X-124A
1.312	1.488	0.140	0.171	0.238	1.313	125	0401CR X-125A
1.375	1.551	0.140	0.171	0.238	1.376	126	0401CR X-126A
1.437	1.613	0.140	0.171	0.238	1.439	127	0401CR X-127A
1.500	1.676	0.140	0.171	0.238	1.502	128	0401CR X-128A
1.562	1.738	0.140	0.171	0.238	1.564	129	0401CR X-129A
1.625	1.801	0.140	0.171	0.238	1.627	130	0401CR X-130A
1.687	1.863	0.140	0.171	0.238	1.689	131	0401CR X-131A
1.750	1.926	0.140	0.171	0.238	1.752	132	0401CR X-132A

\*If used with wear rings, refer to wear ring throat diameter, see Section 9.  
For custom groove calculations, see Appendix C.



Table 5-25. CR Gland Dimensions — Inch (Continued)

A Rod Diameter	B Groove Diameter	C Groove Width (CR0)	C Groove Width (CR1)	C Groove Width (CR2)	D Throat Diameter*	O-ring Dash Number	CR Part Number (X = Groove Width of 0, 1 or 2)
<b>+ .000/- .002</b>	<b>+ .002/- .000</b>	<b>+ .005/- .000</b>	<b>+ .005/- .000</b>	<b>+ .005/- .000</b>	<b>+ .003/- .000</b>		
1.812	1.988	0.140	0.171	0.238	1.814	133	0401CR X-133A
1.875	2.051	0.140	0.171	0.238	1.877	134	0401CR X-134A
1.937	2.113	0.140	0.171	0.238	1.939	135	0401CR X-135A
2.000	2.176	0.140	0.171	0.238	2.002	136	0401CR X-136A
2.062	2.238	0.140	0.171	0.238	2.064	137	0401CR X-137A
2.125	2.301	0.140	0.171	0.238	2.127	138	0401CR X-138A
2.187	2.363	0.140	0.171	0.238	2.189	139	0401CR X-139A
2.250	2.426	0.140	0.171	0.238	2.252	140	0401CR X-140A
2.312	2.488	0.140	0.171	0.238	2.314	141	0401CR X-141A
2.375	2.551	0.140	0.171	0.238	2.377	142	0401CR X-142A
2.437	2.613	0.140	0.171	0.238	2.439	143	0401CR X-143A
2.500	2.676	0.140	0.171	0.238	2.502	144	0401CR X-144A
2.562	2.738	0.140	0.171	0.238	2.564	145	0401CR X-145A
2.625	2.801	0.140	0.171	0.238	2.627	146	0401CR X-146A
2.687	2.863	0.140	0.171	0.238	2.689	147	0401CR X-147A
2.750	2.926	0.140	0.171	0.238	2.752	148	0401CR X-148A
2.812	2.988	0.140	0.171	0.238	2.814	149	0401CR X-149A
2.875	3.051	0.140	0.171	0.238	2.877	150	0401CR X-150A
3.000	3.176	0.140	0.171	0.238	3.002	151	0401CR X-151A
<b>+ .000/- .002</b>	<b>+ .002/- .000</b>	<b>+ .005/- .000</b>	<b>+ .005/- .000</b>	<b>+ .005/- .000</b>	<b>+ .002/- .000</b>		
0.187	0.429	0.187	0.208	0.275	0.188	201	0401CR X-201A
0.250	0.492	0.187	0.208	0.275	0.251	202	0401CR X-202A
0.312	0.554	0.187	0.208	0.275	0.313	203	0401CR X-203A
0.375	0.617	0.187	0.208	0.275	0.376	204	0401CR X-204A
0.437	0.679	0.187	0.208	0.275	0.438	205	0401CR X-205A
0.500	0.742	0.187	0.208	0.275	0.501	206	0401CR X-206A
0.562	0.804	0.187	0.208	0.275	0.563	207	0401CR X-207A
0.625	0.867	0.187	0.208	0.275	0.626	208	0401CR X-208A
0.687	0.929	0.187	0.208	0.275	0.688	209	0401CR X-209A
0.750	0.992	0.187	0.208	0.275	0.751	210	0401CR X-210A
0.812	1.054	0.187	0.208	0.275	0.813	211	0401CR X-211A
0.875	1.117	0.187	0.208	0.275	0.876	212	0401CR X-212A
0.937	1.179	0.187	0.208	0.275	0.938	213	0401CR X-213A
1.000	1.242	0.187	0.208	0.275	1.001	214	0401CR X-214A
1.062	1.304	0.187	0.208	0.275	1.063	215	0401CR X-215A
1.125	1.367	0.187	0.208	0.275	1.126	216	0401CR X-216A
1.187	1.429	0.187	0.208	0.275	1.188	217	0401CR X-217A
1.250	1.492	0.187	0.208	0.275	1.251	218	0401CR X-218A
1.312	1.554	0.187	0.208	0.275	1.313	219	0401CR X-219A
1.375	1.617	0.187	0.208	0.275	1.376	220	0401CR X-220A
1.437	1.679	0.187	0.208	0.275	1.438	221	0401CR X-221A
1.500	1.742	0.187	0.208	0.275	1.501	222	0401CR X-222A
1.625	1.867	0.187	0.208	0.275	1.627	223	0401CR X-223A
1.750	1.992	0.187	0.208	0.275	1.752	224	0401CR X-224A
1.875	2.117	0.187	0.208	0.275	1.877	225	0401CR X-225A
2.000	2.242	0.187	0.208	0.275	2.002	226	0401CR X-226A
2.125	2.367	0.187	0.208	0.275	2.127	227	0401CR X-227A

\*If used with wear rings, refer to wear ring throat diameter, see Section 9.  
For custom groove calculations, see Appendix C.

**Table 5-25. CR Gland Dimensions — Inch (Continued)**

A Rod Diameter	B Groove Diameter	C Groove Width (CR0)	C Groove Width (CR1)	C Groove Width (CR2)	D Throat Diameter*	O-ring Dash Number	CR Part Number (X = Groove Width of 0, 1 or 2)
<b>+0.000/-0.002</b>	<b>+0.002/-0.000</b>	<b>+0.005/-0.000</b>	<b>+0.005/-0.000</b>	<b>+0.005/-0.000</b>	<b>+0.002/-0.000</b>		
2.250	2.492	0.187	0.208	0.275	2.252	228	0401CR X-228A
2.375	2.617	0.187	0.208	0.275	2.377	229	0401CR X-229A
2.500	2.742	0.187	0.208	0.275	2.502	230	0401CR X-230A
2.625	2.867	0.187	0.208	0.275	2.627	231	0401CR X-231A
2.750	2.992	0.187	0.208	0.275	2.752	232	0401CR X-232A
2.875	3.117	0.187	0.208	0.275	2.877	233	0401CR X-233A
3.000	3.242	0.187	0.208	0.275	3.002	234	0401CR X-234A
3.125	3.367	0.187	0.208	0.275	3.127	235	0401CR X-235A
3.250	3.492	0.187	0.208	0.275	3.252	236	0401CR X-236A
3.375	3.617	0.187	0.208	0.275	3.377	237	0401CR X-237A
3.500	3.742	0.187	0.208	0.275	3.502	238	0401CR X-238A
3.625	3.867	0.187	0.208	0.275	3.627	239	0401CR X-239A
3.750	3.992	0.187	0.208	0.275	3.752	240	0401CR X-240A
3.875	4.117	0.187	0.208	0.275	3.877	241	0401CR X-241A
4.000	4.242	0.187	0.208	0.275	4.002	242	0401CR X-242A
4.125	4.367	0.187	0.208	0.275	4.127	243	0401CR X-243A
4.250	4.492	0.187	0.208	0.275	4.252	244	0401CR X-244A
4.375	4.617	0.187	0.208	0.275	4.377	245	0401CR X-245A
4.500	4.742	0.187	0.208	0.275	4.503	246	0401CR X-246A
4.625	4.867	0.187	0.208	0.275	4.628	247	0401CR X-247A
4.750	4.992	0.187	0.208	0.275	4.753	248	0401CR X-248A
4.875	5.117	0.187	0.208	0.275	4.878	249	0401CR X-249A
5.000	5.242	0.187	0.208	0.275	5.003	250	0401CR X-250A
<b>+0.000/-0.002</b>	<b>+0.002/-0.000</b>	<b>+0.005/-0.000</b>	<b>+0.005/-0.000</b>	<b>+0.005/-0.000</b>	<b>+0.002/-0.000</b>		
0.437	0.807	0.281	0.311	0.410	0.439	309	0401CR X-309A
0.500	0.870	0.281	0.311	0.410	0.502	310	0401CR X-310A
0.562	0.932	0.281	0.311	0.410	0.564	311	0401CR X-311A
0.625	0.995	0.281	0.311	0.410	0.627	312	0401CR X-312A
0.687	1.057	0.281	0.311	0.410	0.689	313	0401CR X-313A
0.750	1.120	0.281	0.311	0.410	0.752	314	0401CR X-314A
0.812	1.182	0.281	0.311	0.410	0.814	315	0401CR X-315A
0.875	1.245	0.281	0.311	0.410	0.877	316	0401CR X-316A
0.937	1.307	0.281	0.311	0.410	0.939	317	0401CR X-317A
1.000	1.370	0.281	0.311	0.410	1.002	318	0401CR X-318A
1.062	1.432	0.281	0.311	0.410	1.064	319	0401CR X-319A
1.125	1.495	0.281	0.311	0.410	1.127	320	0401CR X-320A
1.187	1.557	0.281	0.311	0.410	1.189	321	0401CR X-321A
1.250	1.620	0.281	0.311	0.410	1.252	322	0401CR X-322A
1.312	1.682	0.281	0.311	0.410	1.314	323	0401CR X-323A
1.375	1.745	0.281	0.311	0.410	1.377	324	0401CR X-324A
1.500	1.870	0.281	0.311	0.410	1.502	325	0401CR X-325A
1.625	1.995	0.281	0.311	0.410	1.627	326	0401CR X-326A
1.750	2.120	0.281	0.311	0.410	1.752	327	0401CR X-327A
<b>+0.000/-0.002</b>	<b>+0.002/-0.000</b>	<b>+0.005/-0.000</b>	<b>+0.005/-0.000</b>	<b>+0.005/-0.000</b>	<b>+0.002/-0.000</b>		
1.875	2.245	0.281	0.311	0.410	1.878	328	0401CR X-328A
2.000	2.370	0.281	0.311	0.410	2.003	329	0401CR X-329A
2.125	2.495	0.281	0.311	0.410	2.128	330	0401CR X-330A
2.250	2.620	0.281	0.311	0.410	2.253	331	0401CR X-331A

\*If used with wear rings, refer to wear ring throat diameter, see Section 9.  
For custom groove calculations, see Appendix C.

Table 5-25. CR Gland Dimensions — Inch (Continued)

A Rod Diameter	B Groove Diameter	C Groove Width (CR0)	C Groove Width (CR1)	C Groove Width (CR2)	D Throat Diameter*	O-ring Dash Number	CR Part Number (X = Groove Width of 0, 1 or 2)
<b>+ .000/- .002</b>	<b>+ .002/- .000</b>	<b>+ .005/- .000</b>	<b>+ .005/- .000</b>	<b>+ .005/- .000</b>	<b>+ .002/- .000</b>		
2.375	2.745	0.281	0.311	0.410	2.378	332	0401CR X-332A
2.500	2.870	0.281	0.311	0.410	2.503	333	0401CR X-333A
2.625	2.995	0.281	0.311	0.410	2.628	334	0401CR X-334A
2.750	3.120	0.281	0.311	0.410	2.753	335	0401CR X-335A
2.875	3.245	0.281	0.311	0.410	2.878	336	0401CR X-336A
3.000	3.370	0.281	0.311	0.410	3.003	337	0401CR X-337A
3.125	3.495	0.281	0.311	0.410	3.128	338	0401CR X-338A
3.250	3.620	0.281	0.311	0.410	3.253	339	0401CR X-339A
3.375	3.745	0.281	0.311	0.410	3.378	340	0401CR X-340A
3.500	3.870	0.281	0.311	0.410	3.503	341	0401CR X-341A
3.625	3.995	0.281	0.311	0.410	3.628	342	0401CR X-342A
3.750	4.120	0.281	0.311	0.410	3.753	343	0401CR X-343A
3.875	4.245	0.281	0.311	0.410	3.878	344	0401CR X-344A
4.000	4.370	0.281	0.311	0.410	4.003	345	0401CR X-345A
4.125	4.495	0.281	0.311	0.410	4.128	346	0401CR X-346A
4.250	4.620	0.281	0.311	0.410	4.253	347	0401CR X-347A
4.375	4.745	0.281	0.311	0.410	4.378	348	0401CR X-348A
4.500	4.870	0.281	0.311	0.410	4.503	349	0401CR X-349A
4.625	4.995	0.281	0.311	0.410	4.628	350	0401CR X-350A
4.750	5.120	0.281	0.311	0.410	4.753	351	0401CR X-351A
4.875	5.245	0.281	0.311	0.410	4.878	352	0401CR X-352A
5.000	5.370	0.281	0.311	0.410	5.003	353	0401CR X-353A
<b>+ .000/- .002</b>	<b>+ .002/- .000</b>	<b>+ .005/- .000</b>	<b>+ .005/- .000</b>	<b>+ .005/- .000</b>	<b>+ .003/- .000</b>		
4.500	4.974	0.375	0.408	0.538	4.504	425	0401CR X-425A
4.625	5.099	0.375	0.408	0.538	4.629	426	0401CR X-426A
4.750	5.224	0.375	0.408	0.538	4.754	427	0401CR X-427A
4.875	5.349	0.375	0.408	0.538	4.879	428	0401CR X-428A
5.000	5.474	0.375	0.408	0.538	5.004	429	0401CR X-429A
5.125	5.599	0.375	0.408	0.538	5.129	430	0401CR X-430A
5.250	5.724	0.375	0.408	0.538	5.254	431	0401CR X-431A
5.375	5.849	0.375	0.408	0.538	5.379	432	0401CR X-432A
5.500	5.974	0.375	0.408	0.538	5.504	433	0401CR X-433A
5.625	6.099	0.375	0.408	0.538	5.629	434	0401CR X-434A
5.750	6.224	0.375	0.408	0.538	5.754	435	0401CR X-435A
5.875	6.349	0.375	0.408	0.538	5.879	436	0401CR X-436A
6.000	6.474	0.375	0.408	0.538	6.004	437	0401CR X-437A
6.250	6.724	0.375	0.408	0.538	6.254	438	0401CR X-438A
6.500	6.974	0.375	0.408	0.538	6.504	439	0401CR X-439A
6.750	7.224	0.375	0.408	0.538	6.754	440	0401CR X-440A
7.000	7.474	0.375	0.408	0.538	7.004	441	0401CR X-441A
7.250	7.724	0.375	0.408	0.538	7.254	442	0401CR X-442A
7.500	7.974	0.375	0.408	0.538	7.504	443	0401CR X-443A
7.750	8.224	0.375	0.408	0.538	7.754	444	0401CR X-444A
8.000	8.474	0.375	0.408	0.538	8.004	445	0401CR X-445A
8.500	8.974	0.375	0.408	0.538	8.504	446	0401CR X-446A
9.000	9.474	0.375	0.408	0.538	9.004	447	0401CR X-447A
9.500	9.974	0.375	0.408	0.538	9.504	448	0401CR X-448A
10.000	10.474	0.375	0.408	0.538	10.004	449	0401CR X-449A

\*If used with wear rings, refer to wear ring throat diameter, see Section 9.

For custom groove calculations, see Appendix C.

09/01/07



## CR Profile

Table 5-25. CR Gland Dimensions — Inch (Continued)

A Rod Diameter	B Groove Diameter	C Groove Width (CR0)	C Groove Width (CR1)	C Groove Width (CR2)	D Throat Diameter*	O-ring Dash Number	CR Part Number (X = Groove Width of 0, 1 or 2)
<b>+0.000/-0.002</b>	<b>+0.002/-0.000</b>	<b>+0.005/-0.000</b>	<b>+0.005/-0.000</b>	<b>+0.005/-0.000</b>	<b>+0.004/-0.000</b>		
10.500	10.974	0.375	0.408	0.538	10.504	450	<b>0401CR X-450A</b>
11.000	11.474	0.375	0.408	0.538	11.004	451	<b>0401CR X-451A</b>
11.500	11.974	0.375	0.408	0.538	11.504	452	<b>0401CR X-452A</b>
12.000	12.474	0.375	0.408	0.538	12.004	453	<b>0401CR X-453A</b>
12.500	12.974	0.375	0.408	0.538	12.504	454	<b>0401CR X-454A</b>
13.000	13.474	0.375	0.408	0.538	13.004	455	<b>0401CR X-455A</b>
13.500	13.974	0.375	0.408	0.538	13.504	456	<b>0401CR X-456A</b>
14.000	14.474	0.375	0.408	0.538	14.004	457	<b>0401CR X-457A</b>
14.500	14.974	0.375	0.408	0.538	14.504	458	<b>0401CR X-458A</b>
15.000	15.474	0.375	0.408	0.538	15.004	459	<b>0401CR X-459A</b>
15.500	15.974	0.375	0.408	0.538	15.504	460	<b>0401CR X-460A</b>
16.000	16.474	0.375	0.408	0.538	16.004	461	<b>0401CR X-461A</b>

\*If used with wear rings, refer to wear ring throat diameter, [see Section 9](#).

For custom groove calculations, [see Appendix C](#).

NOTE: For sizes larger than those shown in the table, please contact your local Parker Seal representative.

5

# Rod Seal OC Profile

Catalog EPS 5370/USA



## OC Profile, Compact PTFE Rod Cap Seal

The Parker OC profile is a bi-directional rod seal for use in pneumatic and low to medium duty hydraulic systems. The OC profile is a two piece design utilizing a rectangular PTFE cap and standard size Parker o-ring. The OC profile is an excellent choice for applications requiring a compact design. The unique properties of the modified PTFE provide added wear resistance for improved cycle life. Parker's OC profile will retrofit non-Parker seals of similar design.

The OC profile may be ordered without the energizer by omitting the energizer code. See part number nomenclature.

### Technical Data

Standard Materials*		Temperature Range	Pressure Range†	Surface Speed
<b>Cap</b>				
0102	Modified PTFE	-320°F to 450°F (-195°C to 282°C)	1,500 psi (103 bar)	< 13 ft/s (4 m/sec)
<b>Energizer</b>				
A	70A Nitrile	-30°F to 250°F (-34°C to 121°C)		

\***Alternate Materials:** For applications that may require an alternate material, please see Section 3 for alternate PTFE (Table 3-4) and energizer (Table 3-5) materials.

†**Pressure Range** without wear rings (see Table 2-4, page 2-5).

### Options

**Notched side walls:** Notches can be added to the side walls of the PTFE cap. This can help to optimize the seal's response to fluid pressure. Notched side walls help ensure that fluid pressure fills the cavity between the side face of the seal and the side face of the seal gland. Consult your local Parker Seal representative for the availability and cost to add side notches to the OC profile.

N= Notched walls 

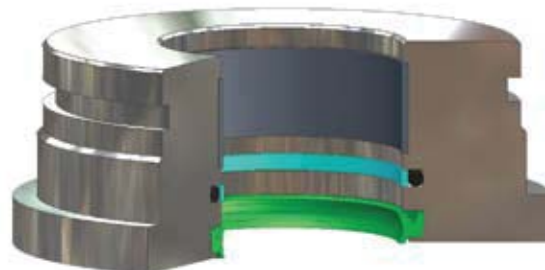

OC installed in Rod Gland

5

09/01/07

## OC Profile

### Part Number Nomenclature — OC Profile

Table 5-26. OC Profile — Inch

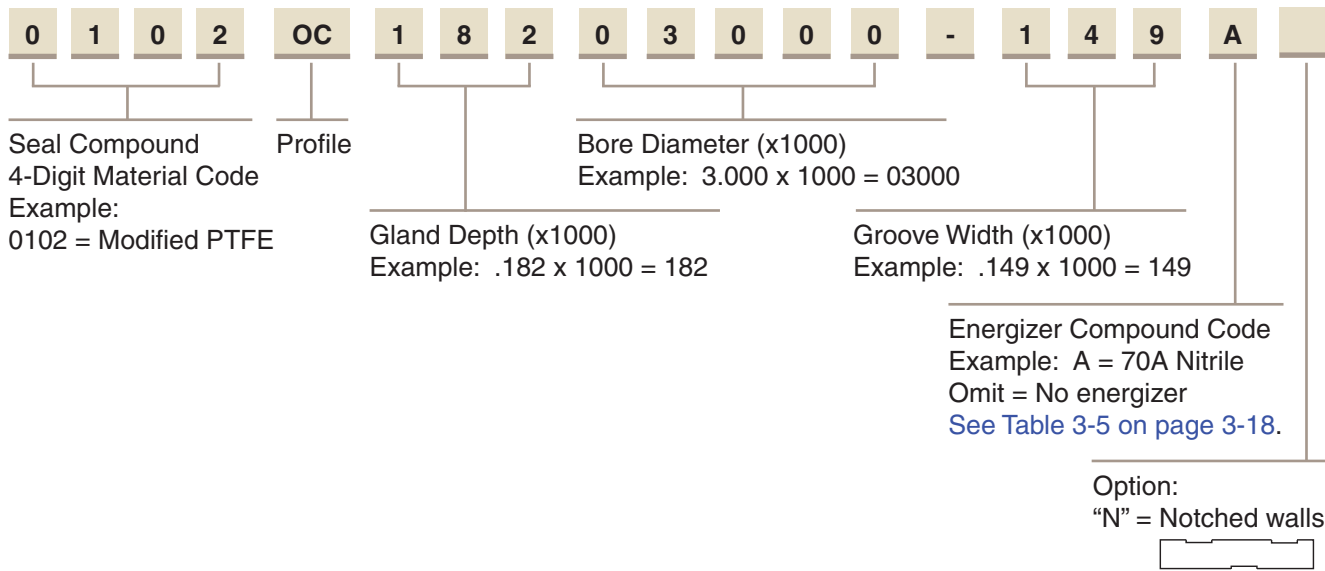

5

### Gland Dimensions — OC Profile

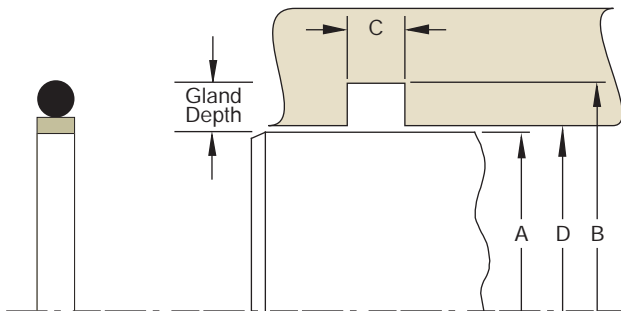

Please refer to Engineering [Section 2](#), [Page 2-8](#) for surface finish and additional hardware considerations.

Table 5-27. OC Profile — Inch

A Rod Diameter	B Groove Diameter	C Groove Width	D Throat Diameter*	O-ring Dash Number	Part Number
+0.000/-0.001	+0.001/-0.000	+0.005/-0.000	+0.002/-0.000		
0.125	0.268	0.079	0.126	007	0102OC07200125-079A
0.156	0.299	0.079	0.157	008	0102OC07200156-079A
0.187	0.331	0.079	0.188	009	0102OC07200187-079A
0.219	0.362	0.079	0.220	010	0102OC07200219-079A
0.250	0.424	0.079	0.251	011	0102OC08700250-079A
0.312	0.487	0.079	0.313	012	0102OC08700312-079A
0.375	0.547	0.079	0.376	013	0102OC08700375-079A
+0.000/-0.002	+0.002/-0.000	+0.005/-0.000	+0.002/-0.000		
0.437	0.610	0.079	0.438	014	0102OC08700437-079A
0.500	0.672	0.079	0.501	015	0102OC08700500-079A
0.562	0.735	0.079	0.563	016	0102OC08700562-079A
0.625	0.797	0.079	0.626	017	0102OC08700675-079A
0.687	0.860	0.079	0.688	018	0102OC08700687-079A

\*If used with wear rings, refer to wear ring throat diameter, see [Section 9](#).  
For custom groove calculations, see [Appendix C](#).

Table 5-27. OC Gland Dimensions — Inch (Continued)

A Rod Diameter	B Groove Diameter	C Groove Width	D Throat Diameter*	O-ring Dash Number	Part Number
<b>+.000/--.002</b>	<b>+.002/--.000</b>	<b>+.005/--.000</b>	<b>+.002/--.000</b>		
0.750	0.922	0.079	0.751	019	0102OC08700750-079A
0.812	0.985	0.079	0.813	020	0102OC08700812-079A
0.875	1.047	0.079	0.876	021	0102OC08700875-079A
0.937	1.110	0.079	0.938	022	0102OC08700937-079A
1.000	1.172	0.079	1.001	023	0102OC08701000-079A
1.062	1.235	0.079	1.063	024	0102OC08701062-079A
1.125	1.298	0.079	1.126	025	0102OC08701125-079A
1.188	1.360	0.079	1.189	026	0102OC08701188-079A
1.250	1.422	0.079	1.251	027	0102OC08701250-079A
1.312	1.485	0.079	1.313	028	0102OC08701312-079A
<b>+.000/--.003</b>	<b>+.003/--.000</b>	<b>+.005/--.000</b>	<b>+.002/--.000</b>		
0.375	0.611	0.112	0.376	111	0102OC11800375-112A
0.437	0.674	0.112	0.438	112	0102OC11800437-112A
0.500	0.736	0.112	0.501	113	0102OC11800500-112A
0.562	0.799	0.112	0.563	114	0102OC11800562-112A
0.625	0.862	0.112	0.626	115	0102OC11800625-112A
0.687	0.924	0.112	0.688	116	0102OC11800687-112A
0.750	0.986	0.112	0.751	117	0102OC11800750-112A
0.812	1.049	0.112	0.813	118	0102OC11800812-112A
0.875	1.111	0.112	0.876	119	0102OC11800875-112A
0.937	1.174	0.112	0.938	120	0102OC11800937-112A
1.000	1.236	0.112	1.001	121	0102OC11801000-112A
1.062	1.299	0.112	1.063	122	0102OC11801062-112A
1.125	1.362	0.112	1.126	123	0102OC11801125-112A
1.187	1.424	0.112	1.188	124	0102OC11801187-112A
1.250	1.486	0.112	1.251	125	0102OC11801250-112A
1.312	1.549	0.112	1.313	126	0102OC11801312-112A
1.375	1.611	0.112	1.376	127	0102OC11801375-112A
1.437	1.674	0.112	1.438	128	0102OC11801437-112A
1.500	1.736	0.112	1.501	129	0102OC11801500-112A
1.562	1.799	0.112	1.563	130	0102OC11801562-112A
1.625	1.862	0.112	1.626	131	0102OC11801625-112A
1.687	1.924	0.112	1.688	132	0102OC11801687-112A
1.750	1.986	0.112	1.751	133	0102OC11801750-112A
1.812	2.049	0.112	1.813	134	0102OC11801812-112A
1.875	2.111	0.112	1.876	135	0102OC11801875-112A
1.937	2.174	0.112	1.938	136	0102OC11801937-112A
2.000	2.236	0.112	2.001	137	0102OC11802000-112A
2.062	2.299	0.112	2.063	138	0102OC11802062-112A
2.125	2.632	0.112	2.126	139	0102OC11802125-112A
2.187	2.424	0.112	2.188	140	0102OC11802187-112A
2.250	2.486	0.112	2.251	141	0102OC11802250-112A
2.312	2.549	0.112	2.313	142	0102OC11802312-112A
2.375	2.611	0.112	2.376	143	0102OC11802375-112A
2.437	2.674	0.112	2.438	144	0102OC11802437-112A
2.500	2.736	0.112	2.501	145	0102OC11802500-112A
2.562	2.799	0.112	2.563	146	0102OC11802562-112A

\*If used with wear rings, refer to wear ring throat diameter, see Section 9.  
For custom groove calculations, see Appendix C.



**OC Profile**

**Table 5-27. OC Gland Dimensions — Inch (Continued)**

A Rod Diameter	B Groove Diameter	C Groove Width	D Throat Diameter*	O-ring Dash Number	Part Number
<b>+ .000/- .003</b>	<b>+ .003/- .000</b>	<b>+ .005/- .000</b>	<b>+ .002/- .000</b>		
2.625	2.862	0.112	2.626	147	0102OC11802625-112A
2.687	2.924	0.112	2.688	148	0102OC11802687-112A
2.750	2.986	0.112	2.751	149	0102OC11802750-112A
<b>+ .000/- .004</b>	<b>+ .004/- .000</b>	<b>+ .005/- .000</b>	<b>+ .002/- .000</b>		
0.750	1.050	0.149	0.751	211	0102OC15000750-149A
0.812	1.113	0.149	0.813	212	0102OC15000812-149A
0.875	1.175	0.149	0.876	213	0102OC15000875-149A
0.937	1.238	0.149	0.938	214	0102OC15000937-149A
1.000	1.300	0.149	1.001	215	0102OC15001000-149A
1.062	1.363	0.149	1.063	216	0102OC15001062-149A
1.125	1.426	0.149	1.126	217	0102OC15001125-149A
1.187	1.488	0.149	1.188	218	0102OC15001187-149A
1.250	1.550	0.149	1.251	219	0102OC15001250-149A
1.312	1.613	0.149	1.313	220	0102OC15001312-149A
1.375	1.675	0.149	1.376	221	0102OC15001375-149A
1.437	1.738	0.149	1.438	222	0102OC15001437-149A
1.500	1.863	0.149	1.501	223	0102OC18201500-149A
1.625	1.988	0.149	1.626	224	0102OC18201625-149A
1.750	2.113	0.149	1.751	225	0102OC18201750-149A
1.875	2.238	0.149	1.876	226	0102OC18201875-149A
2.000	2.363	0.149	2.001	227	0102OC18202000-149A
2.125	2.488	0.149	2.126	228	0102OC18202125-149A
2.250	2.613	0.149	2.251	229	0102OC18202250-149A
2.375	2.738	0.149	2.376	230	0102OC18202375-149A
2.500	2.863	0.149	2.501	231	0102OC18202500-149A
2.625	2.988	0.149	2.626	232	0102OC18202625-149A
2.750	3.113	0.149	2.751	233	0102OC18202750-149A
2.875	3.238	0.149	2.876	234	0102OC18202875-149A
3.000	3.363	0.149	3.001	235	0102OC18203000-149A
3.125	3.488	0.149	3.126	236	0102OC18203125-149A
3.250	3.613	0.149	3.251	237	0102OC18203250-149A
3.375	3.738	0.149	3.376	238	0102OC18203375-149A
3.500	3.863	0.149	3.501	239	0102OC18203500-149A
3.625	3.988	0.149	3.626	240	0102OC18203625-149A
3.750	4.113	0.149	3.751	241	0102OC18203750-149A
3.875	4.238	0.149	3.876	242	0102OC18203875-149A
4.000	4.363	0.149	4.001	243	0102OC18204000-149A
4.125	4.488	0.149	4.126	244	0102OC18204125-149A
4.250	4.613	0.149	4.251	245	0102OC18204250-149A
4.375	4.738	0.149	4.376	246	0102OC18204375-149A
4.500	4.863	0.149	4.501	247	0102OC18204500-149A
4.625	4.988	0.149	4.626	248	0102OC18204625-149A
<b>+ .000/- .005</b>	<b>+ .005/- .000</b>	<b>+ .005/- .000</b>	<b>+ .003/- .000</b>		
1.500	1.991	0.221	1.501	326	0102OC24601500-221A
1.625	2.116	0.221	1.626	327	0102OC24601625-221A
1.750	2.241	0.221	1.751	328	0102OC24601750-221A
1.875	2.366	0.221	1.876	329	0102OC24601875-221A
2.000	2.491	0.221	2.001	330	0102OC24602000-221A

\*If used with wear rings, refer to wear ring throat diameter, see Section 9.  
For custom groove calculations, see Appendix C.



Table 5-27. OC Gland Dimensions — Inch (Continued)

A Rod Diameter	B Groove Diameter	C Groove Width	D Throat Diameter*	O-ring Dash Number	Part Number
<b>+.000/--.005</b>	<b>+.005/--.000</b>	<b>+.005/--.000</b>	<b>+.003/--.000</b>		
2.125	2.616	0.221	2.126	331	0102OC24602125-221A
2.250	2.741	0.221	2.251	332	0102OC24602250-221A
2.375	2.866	0.221	2.376	333	0102OC24602375-221A
2.500	2.991	0.221	2.501	334	0102OC24602500-221A
2.625	3.116	0.221	2.626	335	0102OC24602625-221A
2.750	3.241	0.221	2.751	336	0102OC24602750-221A
2.875	3.366	0.221	2.876	337	0102OC24602875-221A
3.000	3.491	0.221	3.001	338	0102OC24603000-221A
3.125	3.616	0.221	3.126	339	0102OC24603125-221A
3.250	3.741	0.221	3.251	340	0102OC24603250-221A
3.375	3.866	0.221	3.376	341	0102OC24603375-221A
3.500	3.991	0.221	3.501	342	0102OC24603500-221A
3.625	4.116	0.221	3.626	343	0102OC24603625-221A
3.750	4.241	0.221	3.751	344	0102OC24603750-221A
3.875	4.366	0.221	3.876	345	0102OC24603875-221A
4.000	4.491	0.221	4.001	346	0102OC24604000-221A
4.125	4.616	0.221	4.126	347	0102OC24604125-221A
4.250	4.741	0.221	4.251	348	0102OC24604250-221A
4.375	4.866	0.221	4.376	349	0102OC24604375-221A
<b>+.000/--.006</b>	<b>+.006/--.000</b>	<b>+.005/--.000</b>	<b>+.004/--.000</b>		
4.500	5.093	0.297	4.502	426	0102OC29704500-297A
4.625	5.218	0.297	4.627	427	0102OC29704625-297A
4.750	5.343	0.297	4.752	428	0102OC29704750-297A
4.875	5.468	0.297	4.877	429	0102OC29704875-297A
5.000	5.593	0.297	5.002	430	0102OC29705000-297A
5.125	5.718	0.297	5.127	431	0102OC29705125-297A
5.250	5.843	0.297	5.252	432	0102OC29705250-297A
5.375	5.968	0.297	5.377	433	0102OC29705375-297A
5.500	6.093	0.297	5.502	434	0102OC29705500-297A
5.625	6.218	0.297	5.627	435	0102OC29705625-297A
5.750	6.343	0.297	5.752	436	0102OC29705750-297A
5.875	6.468	0.297	5.877	437	0102OC29705875-297A
6.000	6.718	0.297	6.002	438	0102OC35906000-297A
6.250	6.968	0.297	6.252	439	0102OC35906250-297A
6.500	7.218	0.297	6.502	440	0102OC35906500-297A
6.750	7.468	0.297	6.752	441	0102OC35906750-297A
7.000	7.718	0.297	7.002	442	0102OC35907000-297A
7.250	7.968	0.297	7.252	443	0102OC35907250-297A
7.500	8.218	0.297	7.502	444	0102OC35907500-297A
7.750	8.468	0.297	7.752	445	0102OC35907750-297A
<b>+.000/--.006</b>	<b>+.006/--.000</b>	<b>+.005/--.000</b>	<b>+.005/--.000</b>		
8.000	8.968	0.297	8.002	446	0102OC48408000-297A
8.500	9.468	0.297	8.502	447	0102OC48408500-297A
9.000	9.968	0.297	9.002	448	0102OC48409000-297A
9.500	10.468	0.297	9.502	449	0102OC48409500-297A
10.000	10.968	0.297	10.002	450	0102OC48410000-297A
10.500	11.468	0.297	10.502	451	0102OC48410500-297A
11.000	11.968	0.297	11.002	452	0102OC48411000-297A

\*If used with wear rings, refer to wear ring throat diameter, see Section 9.

For custom groove calculations, see Appendix C.

**OC Profile**

**Table 5-27. OC Gland Dimensions — Inch (Continued)**

A Rod Diameter	B Groove Diameter	C Groove Width	D Throat Diameter*	O-ring Dash Number	Part Number
<b>+ .000/- .006</b>	<b>+ .006/- .000</b>	<b>+ .005/- .000</b>	<b>+ .005/- .000</b>		
11.500	12.468	0.297	11.502	453	<b>0102OC48411500-297A</b>
12.000	12.968	0.297	12.002	454	<b>0102OC48412000-297A</b>
12.500	13.468	0.297	12.502	455	<b>0102OC48412500-297A</b>
13.000	13.968	0.297	13.002	456	<b>0102OC48413000-297A</b>
13.500	14.468	0.297	13.502	457	<b>0102OC48413500-297A</b>
14.000	14.968	0.297	14.002	458	<b>0102OC48414000-297A</b>
14.500	15.468	0.297	14.502	459	<b>0102OC48414500-297A</b>
15.000	15.968	0.297	15.002	460	<b>0102OC48415000-297A</b>

\*If used with wear rings, refer to wear ring throat diameter, [see Section 9](#).

For custom groove calculations, [see Appendix C](#).

NOTE: For sizes larger than those shown in the table, please contact your local Parker Seal representative.

# Rod Seal BR Profile

Catalog EPS 5370/USA



## BR Profile, Premium Buffer Seal

The BR profile is a compact rod seal designed to act as a buffer seal for the primary rod seal. As a buffer seal, the BR profile provides the majority of the rod sealing performance while allowing fluid to by pass onto and energize the primary rod seal. Fluid located between the BR profile and the rod seal will relieve back into the cylinder by flowing past the BR profile's flexible static side lip and slotted pedestals. This relieving or check valve function allows the BR profile and primary rod seal to work as a sealing system without the danger of developing a pressure trap. As a sealing system, the BR profile and primary rod seal provide optimal performance in the most difficult applications.

5

### Technical Data

Standard Materials*	Temperature Range	Pressure Range†	Surface Speed
P4300A90	-65°F to 275°F (-54°C to 135°C)	5000 psi (344 bar)	< 1.6 ft/s (0.5 m/s)

\***Alternate Materials:** For applications that may require an alternate material, please contact your local Parker Seal representative.

†**Pressure Range** without wear rings (see Table 2-4, page 2-5).



*BR Cross-Section  
with Back-up*



*BR Cross-Section  
without Back-up*

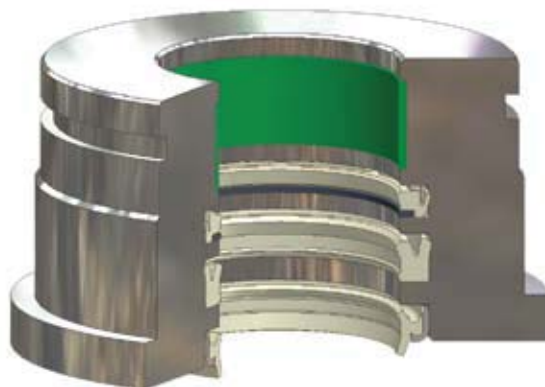

*BR Installed in Rod Gland*

02/15/08

## BR Profile

### Part Number Nomenclature — BR Profile

Table 5-28. BR Profile — Inch

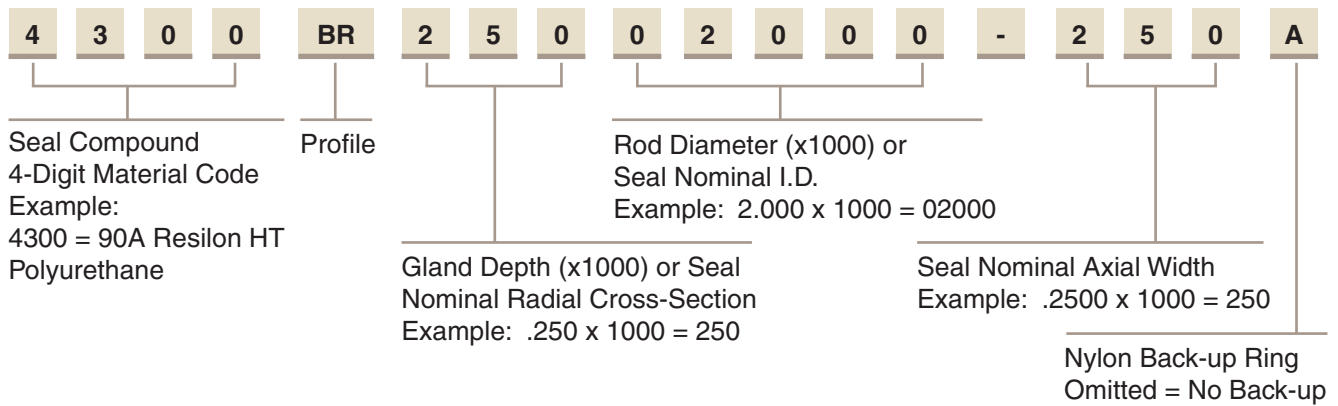

### Gland Dimensions — BR Profile

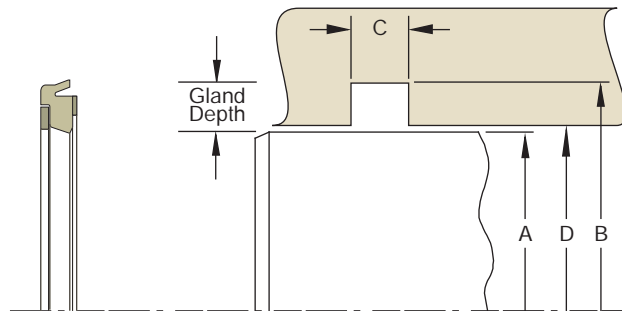

Table 5-29. Gland Dimension Tolerances

Nominal Gland Depth	A Rod Diameter	B Groove Diameter	C Groove Width	D Throat Diameter
1/8	+0.000/-0.001	+0.002/-0.000	+0.010/-0.000	+0.002/-0.000
3/16	+0.000/-0.002	+0.002/-0.000		+0.002/-0.000
1/4	+0.000/-0.002	+0.003/-0.000		+0.003/-0.000
5/16	+0.000/-0.002	+0.004/-0.000		+0.003/-0.000
3/8	+0.000/-0.002	+0.005/-0.000		+0.004/-0.000
7/16	+0.000/-0.003	+0.006/-0.000		+0.004/-0.000
1/2	+0.000/-0.003	+0.007/-0.000		+0.005/-0.000
5/8	+0.000/-0.003	+0.009/-0.000		+0.006/-0.000
3/4	+0.000/-0.004	+0.011/-0.000		+0.007/-0.000
1	+0.000/-0.005	+0.015/-0.000		+0.009/-0.000

Please refer to Engineering Section 2, Page 2-8 for surface finish and additional hardware considerations.

Table 5-30. BR Gland Dimensions — Inch

A Rod Diameter	B Groove Diameter	C Groove Width	D Throat Diameter*	Part Number	
1.000	1.374	0.205	1.001	4300	BR18701000-187A
1.125	1.499	0.205	1.126	4300	BR18701125-187A
1.250	1.624	0.205	1.251	4300	BR18701250-187A
1.250	1.812	0.135	1.251	4300	BR28101250-135
1.375	1.749	0.205	1.376	4300	BR18701375-187A
1.375	1.937	0.135	1.376	4300	BR28101375-135

\*If used with wear rings, refer to wear ring throat diameter, see Section 9. For custom groove calculations, see Appendix C.

Table 5-30. BR Gland Dimensions — Inch (Continued)

A Rod Diameter	B Groove Diameter	C Groove Width	D Throat Diameter*	Part Number	
1.500	2.000	0.275	1.501	4300	BR25001500-250A
1.500	2.062	0.135	1.501	4300	BR28101500-135
1.750	2.250	0.275	1.751	4300	BR25001750-250A
1.750	2.312	0.135	1.751	4300	BR28101750-135
2.000	2.500	0.275	2.001	4300	BR25002000-250A
2.000	2.562	0.135	2.001	4300	BR28102000-135
2.250	2.926	0.252	2.251	4300	BR33802250-229A
2.500	3.000	0.275	2.501	4300	BR25002500-250A
2.500	3.174	0.252	2.502	4300	BR33702500-229A
2.750	3.397	0.252	2.752	4300	BR32402750-229A
3.000	3.500	0.275	3.001	4300	BR25003000-250A
3.500	4.000	0.275	3.501	4300	BR25003500-250A
3.500	4.166	0.252	3.502	4300	BR33303500-229A
3.750	4.250	0.275	3.751	4300	BR25003750-250A
4.000	4.624	0.343	4.002	4300	BR31204000-312A
4.000	4.666	0.252	4.002	4300	BR33304000-229A
4.250	4.750	0.275	4.251	4300	BR25004250-250A
4.250	4.866	0.275	4.252	4300	BR30804250-250A
4.500	5.124	0.343	4.502	4300	BR31204500-312A
4.750	5.500	0.412	4.752	4300	BR37504750-375A
5.000	5.750	0.412	5.002	4300	BR37505000-375A
5.000	5.830	0.358	5.002	4300	BR41505000-325A
5.500	6.250	0.412	5.502	4300	BR37505500-375A
5.750	6.250	0.275	5.751	4300	BR25005750-250A
9.000	10.000	0.550	9.002	4300	BR50009000-500A

\*If used with wear rings, refer to wear ring throat diameter, [see Section 9](#).

For custom groove calculations, [see Appendix C](#).

NOTE: For sizes larger than those shown in the table, please contact your local Parker Seal representative.

# Rod Seal OD Profile

Catalog EPS 5370/USA

5



OD Cross-Section

## OD Profile, PTFE Buffer Seal

The Parker OD profile is a rod seal that can be used as a buffer seal in conjunction with a primary rod seal or in tandem with itself to form a sealing system for higher performance. The OD profile is a uni-directional seal, with a unique design that allows trapped fluid pressure back into the cylinder. When the rod extends from the cylinder the OD profile is riding on a sealing point, creating a high compression point to limit leakage. As the rod goes through its return stroke this seal rocks forward, creating a larger sealing surface on the rod. The compression force is spread out over a larger area allowing trapped fluid to pass under the seal and return to the system. This pressure relief feature allows the OD profile to be used in tandem or multiple seal arrangements. The OD features low friction, long life, and versatility.

The OD profile may be ordered without the energizer by omitting the energizer code. See part number nomenclature.

### Technical Data

Standard Materials*	Temperature Range	Pressure Range†	Surface Speed
<b>Cap</b>			
0401 40% bronze-filled PTFE	-200°F to 575°F (-129°C to 302°C)	5000 psi (344 bar)	< 13 ft/s (4 m/sec)
<b>Energizer</b>			
A 70A Nitrile	-30°F to 250°F (-34°C to 121°C)		

\***Alternate Materials:** For applications that may require an alternate material, please see Section 3 for alternate PTFE (Table 3-4) and energizer (Table 3-5) materials.

†**Pressure Range** without wear rings (see Table 2-4, page 2-5).

### Options

**Metric:** To configure metric part numbering, see Table 5-34 on page 5-52.

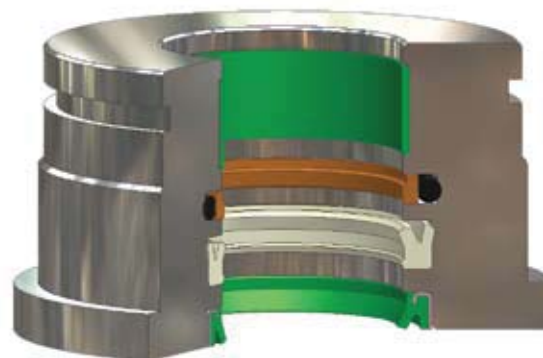

OD installed in Rod Gland

09/01/07

### Part Number Nomenclature — OD Profile

Table 5-31. OD Profile — Inch

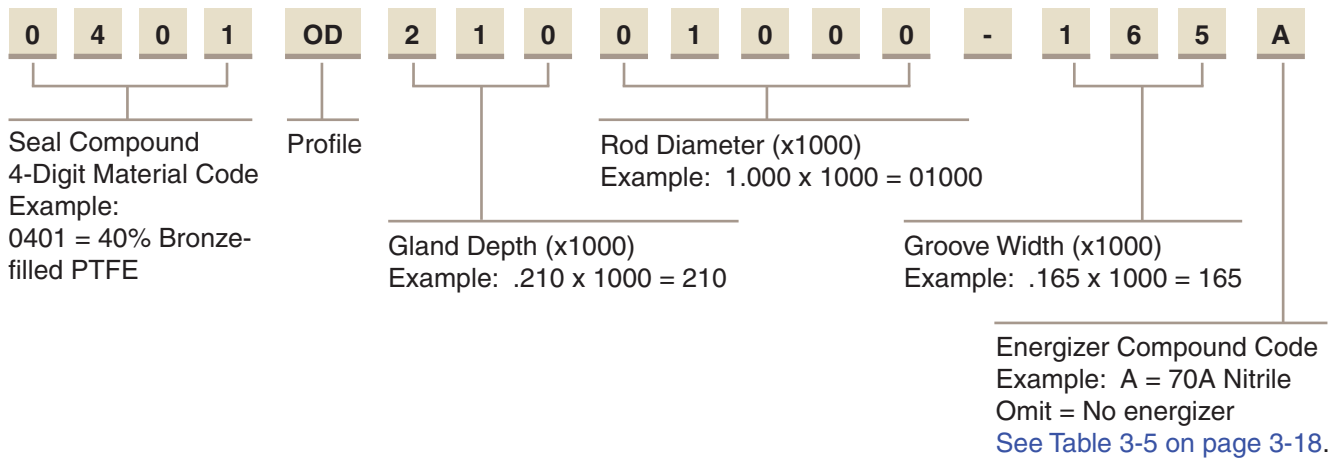

### Gland Dimensions — OD Profile

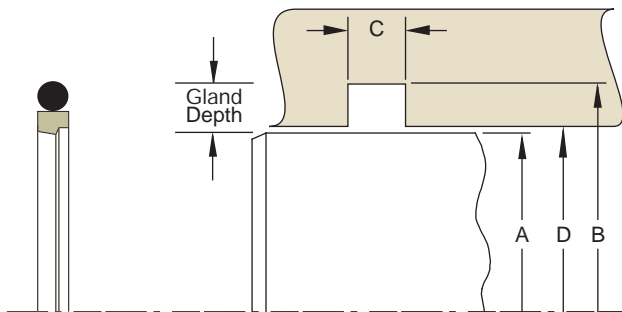

Please refer to Engineering [Section 2, Page 2-8](#) for surface finish and additional hardware considerations.

Table 5-32. OD Profile — Inch

A Rod Diameter	B Groove Diameter	C Groove Width	D Throat Diameter*	O-ring Dash Number	Part Number
+ .000 / - .001	+ .001 / - .000	+ .008 / - .000	+ .002 / - .000		
0.313	0.599	0.126	0.314	111	0401OD14300313-126A
0.375	0.661	0.126	0.376	112	0401OD14300375-126A
+ .000 / - .002	+ .002 / - .000	+ .008 / - .000	+ .002 / - .000		
0.438	0.724	0.126	0.439	113	0401OD14300438-126A
0.500	0.786	0.126	0.501	114	0401OD14300500-126A
0.563	0.849	0.126	0.564	115	0401OD14300563-126A
0.625	0.911	0.126	0.626	116	0401OD14300625-126A
0.688	0.974	0.126	0.689	117	0401OD14300688-126A
+ .000 / - .002	+ .002 / - .000	+ .008 / - .000	+ .002 / - .000		
0.750	1.170	0.165	0.751	213	0401OD21000750-165A
0.813	1.233	0.165	0.814	214	0401OD21000813-165A
0.875	1.295	0.165	0.876	215	0401OD21000875-165A
0.938	1.358	0.165	0.939	216	0401OD21000938-165A
1.000	1.420	0.165	1.001	217	0401OD21001000-165A
1.063	1.483	0.165	1.064	218	0401OD21001063-165A
1.125	1.545	0.165	1.126	219	0401OD21001125-165A
1.188	1.608	0.165	1.189	220	0401OD21001188-165A
1.250	1.670	0.165	1.251	221	0401OD21001250-165A
1.313	1.733	0.165	1.314	222	0401OD21001313-165A

\*If used with wear rings, refer to wear ring throat diameter, see [Section 9](#).  
For custom groove calculations, see [Appendix C](#).





**OD Profile**

**Table 5-32. OD Gland Dimensions — Inch (Continued)**

A Rod Diameter	B Groove Diameter	C Groove Width	D Throat Diameter*	O-ring Dash Number	Part Number
<b>+.000 / -.002</b>	<b>+.002/-.000</b>	<b>+.008/-.000</b>	<b>+.002/-.000</b>		
1.375	1.795	0.165	1.376	222	0401OD21001375-165A
1.438	1.858	0.165	1.439	223	0401OD21001438-165A
<b>+.000 / -.002</b>	<b>+.002/-.000</b>	<b>+.008/-.000</b>	<b>+.003/-.000</b>		
1.500	2.094	0.248	1.501	327	0401OD29701500-248A
1.563	2.157	0.248	1.564	327	0401OD29701563-248A
1.625	2.219	0.248	1.626	328	0401OD29701625-248A
1.688	2.282	0.248	1.689	328	0401OD29701688-248A
1.750	2.344	0.248	1.751	329	0401OD29701750-248A
1.813	2.407	0.248	1.814	329	0401OD29701813-248A
1.875	2.469	0.248	1.876	330	0401OD29701875-248A
1.938	2.532	0.248	1.939	330	0401OD29701938-248A
<b>+.000 / -.003</b>	<b>+.003/-.000</b>	<b>+.008/-.000</b>	<b>+.003/-.000</b>		
2.000	2.594	0.248	2.001	331	0401OD29702000-248A
2.125	2.719	0.248	2.126	332	0401OD29702125-248A
2.250	2.844	0.248	2.251	333	0401OD29702250-248A
2.375	2.969	0.248	2.376	334	0401OD29702375-248A
2.500	3.094	0.248	2.501	335	0401OD29702500-248A
2.625	3.219	0.248	2.626	336	0401OD29702625-248A
2.750	3.344	0.248	2.751	337	0401OD29702750-248A
2.875	3.469	0.248	2.876	338	0401OD29702875-248A
3.000	3.594	0.248	3.001	339	0401OD29703000-248A
3.125	3.719	0.248	3.126	340	0401OD29703125-248A
3.250	3.844	0.248	3.251	341	0401OD29703250-248A
3.375	3.969	0.248	3.376	342	0401OD29703375-248A
3.500	4.094	0.248	3.501	343	0401OD29703500-248A
3.625	4.219	0.248	3.626	344	0401OD29703625-248A
3.750	4.344	0.248	3.751	345	0401OD29703750-248A
3.875	4.469	0.248	3.876	346	0401OD29703875-248A
4.000	4.594	0.248	4.001	347	0401OD29704000-248A
4.125	4.719	0.248	4.126	348	0401OD29704125-248A
4.250	4.844	0.248	4.251	349	0401OD29704250-248A
4.375	4.969	0.248	4.376	350	0401OD29704375-248A
4.500	5.094	0.248	4.501	351	0401OD29704500-248A
4.625	5.219	0.248	4.626	352	0401OD29704625-248A
<b>+.000 / -.004</b>	<b>+.004/-.000</b>	<b>+.008/-.000</b>	<b>+.003/-.000</b>		
4.750	5.344	0.248	4.752	353	0401OD29704750-248A
4.875	5.469	0.248	4.877	354	0401OD29704875-248A
5.000	5.594	0.248	5.002	355	0401OD29705000-248A
5.125	5.719	0.248	5.127	356	0401OD29705125-248A
5.250	5.844	0.248	5.252	357	0401OD29705250-248A
5.375	5.969	0.248	5.377	358	0401OD29705375-248A
5.500	6.094	0.248	5.502	359	0401OD29705500-248A
5.625	6.219	0.248	5.627	360	0401OD29705625-248A
5.750	6.344	0.248	5.752	361	0401OD29705750-248A
6.000	6.594	0.248	6.002	362	0401OD29706000-248A
6.250	6.844	0.248	6.252	363	0401OD29706250-248A
6.500	7.094	0.248	6.502	364	0401OD29706500-248A
6.750	7.344	0.248	6.752	365	0401OD29706750-248A
7.000	7.594	0.248	7.002	366	0401OD29707000-248A

\*If used with wear rings, refer to wear ring throat diameter, see Section 9.  
For custom groove calculations, see Appendix C.



Table 5-32. OD Gland Dimensions — Inch (Continued)

A Rod Diameter	B Groove Diameter	C Groove Width	D Throat Diameter*	O-ring Dash Number	Part Number
<b>+ .000 / - .005</b>	<b>+ .005 / - .000</b>	<b>+ .008 / - .000</b>	<b>+ .003 / - .000</b>		
7.250	7.844	0.248	7.252	367	0401OD29707250-248A
7.500	8.094	0.248	7.502	368	0401OD29707500-248A
7.750	8.344	0.248	7.752	369	0401OD29707750-248A
<b>+ .000 / - .005</b>	<b>+ .005 / - .000</b>	<b>+ .008 / - .000</b>	<b>+ .004 / - .000</b>		
8.000	8.806	0.319	8.003	445	0401OD40308000-319A
8.250	9.056	0.319	8.253	446	0401OD40308250-319A
8.500	9.306	0.319	8.503	446	0401OD40308500-319A
8.750	9.556	0.319	8.753	447	0401OD40308750-319A
9.000	9.806	0.319	9.003	447	0401OD40309000-319A
9.250	10.056	0.319	9.253	448	0401OD40309250-319A
9.500	10.306	0.319	9.503	448	0401OD40309500-319A
9.750	10.556	0.319	9.753	449	0401OD40309750-319A
<b>+ .000 / - .005</b>	<b>+ .005 / - .000</b>	<b>+ .008 / - .000</b>	<b>+ .005 / - .000</b>		
10.000	10.944	0.319	10.003	450	0401OD47210000-319A
10.500	11.444	0.319	10.503	451	0401OD47210500-319A
11.000	11.944	0.319	11.003	452	0401OD47211000-319A
11.500	12.444	0.319	11.503	453	0401OD47211500-319A
12.000	12.944	0.319	12.003	454	0401OD47212000-319A
<b>+ .000 / - .006</b>	<b>+ .006 / - .000</b>	<b>+ .008 / - .000</b>	<b>+ .005 / - .000</b>		
12.500	13.444	0.319	12.503	454	0401OD47212500-319A
13.000	13.944	0.319	13.003	455	0401OD47213000-319A
13.500	14.444	0.319	13.503	456	0401OD47213500-319A
14.000	14.944	0.319	14.003	457	0401OD47214000-319A
14.500	15.444	0.319	14.503	458	0401OD47214500-319A
15.000	15.944	0.319	15.003	459	0401OD47215000-319A
15.500	16.444	0.319	15.503	460	0401OD47215500-319A
16.000	16.944	0.319	16.003	461	0401OD47216000-319A
16.500	17.444	0.319	16.503	462	0401OD47216500-319A
17.000	17.944	0.319	17.003	463	0401OD47217000-319A
17.500	18.444	0.319	17.503	464	0401OD47217500-319A
18.000	18.944	0.319	18.003	465	0401OD47218000-319A
18.500	19.444	0.319	18.503	466	0401OD47218500-319A
19.000	19.944	0.319	19.003	467	0401OD47219000-319A
19.500	20.444	0.319	19.503	468	0401OD47219500-319A
<b>+ .000 / - .007</b>	<b>+ .007 / - .000</b>	<b>+ .008 / - .000</b>	<b>+ .001 / - .000</b>		
20.000	20.944	0.319	20.003	469	0401OD47220000-319A

\*If used with wear rings, refer to wear ring throat diameter, see Section 9.

For custom groove calculations, see Appendix C.

NOTE: For sizes larger than those shown in the table, please contact your local Parker Seal representative.

## OD Profile

### Part Number Nomenclature — OD Profile

Table 5-33. OD Profile — Metric

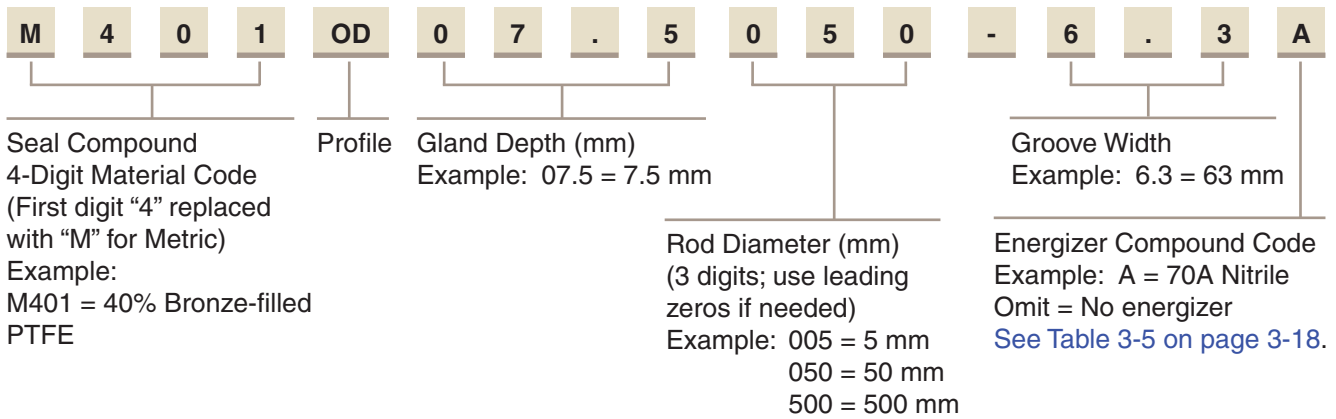

### Gland Dimensions — OD Profile

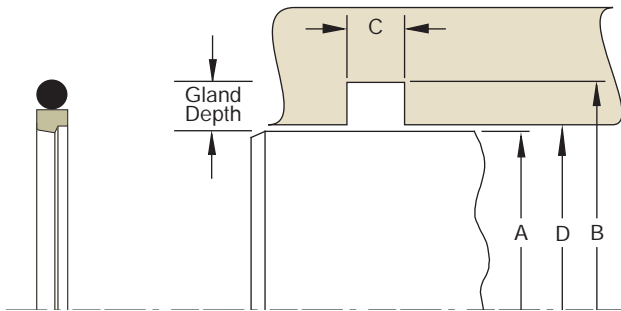

Please refer to Engineering [Section 2](#), [Page 2-8](#) for surface finish and additional hardware considerations.

Table 5-34. OD Profile — Metric

A Rod Diameter	B Groove Diameter	C Groove Width	D Throat Diameter*	O-ring Dash Number	Part Number
f7	H9	+0.20/-0.00	H8		
For ISO tolerances refer to Appendix F.					
8.0	15.2	3.2	8.0	111	M401OD03.6008-3.2A
10.0	17.2	3.2	10.0	112	M401OD03.6010-3.2A
12.0	19.2	3.2	12.0	113	M401OD03.6012-3.2A
14.0	21.2	3.2	14.0	114	M401OD03.6014-3.2A
15.0	22.2	3.2	15.0	115	M401OD03.6015-3.2A
16.0	23.2	3.2	16.0	116	M401OD03.6016-3.2A
18.0	25.2	3.2	18.0	117	M401OD03.6018-3.2A
20.0	30.6	4.2	20.0	213	M401OD05.3020-4.2A
22.0	32.6	4.2	22.0	215	M401OD05.3022-4.2A
25.0	35.6	4.2	25.0	217	M401OD05.3025-4.2A
28.0	38.6	4.2	28.0	219	M401OD05.3028-4.2A
30.0	40.6	4.2	30.0	220	M401OD05.3030-4.2A
32.0	42.6	4.2	32.0	221	M401OD05.3032-4.2A
35.0	45.6	4.2	35.0	222	M401OD05.3035-4.2A
36.0	46.6	4.2	36.0	223	M401OD05.3036-4.2A
40.0	55.0	6.3	40.0	327	M401OD07.5040-6.3A
42.0	57.0	6.3	42.0	328	M401OD07.5042-6.3A
45.0	60.0	6.3	45.0	329	M401OD07.5045-6.3A

\*If used with wear rings, refer to wear ring throat diameter, [see Section 9](#).  
For custom groove calculations, [see Appendix C](#).

Table 5-34. OD Gland Dimensions — Metric (continued)

A Rod Diameter	B Groove Diameter	C Groove Width	D Throat Diameter*	O-ring Dash Number	Part Number
f7	H9	+ .20/- .00	H8		
For ISO tolerances refer to Appendix F.					
48.0	63.0	6.3	48.0	330	M401OD07.5048-6.3A
50.0	65.0	6.3	50.0	331	M401OD07.5050-6.3A
52.0	67.0	6.3	52.0	331	M401OD07.5052-6.3A
55.0	70.0	6.3	55.0	332	M401OD07.5055-6.3A
56.0	71.0	6.3	56.0	333	M401OD07.5056-6.3A
60.0	75.0	6.3	60.0	334	M401OD07.5060-6.3A
63.0	78.0	6.3	63.0	335	M401OD07.5063-6.3A
65.0	80.0	6.3	65.0	335	M401OD07.5065-6.3A
70.0	85.0	6.3	70.0	337	M401OD07.5070-6.3A
75.0	90.0	6.3	75.0	339	M401OD07.5075-6.3A
80.0	95.0	6.3	80.0	340	M401OD07.5080-6.3A
85.0	100.0	6.3	85.0	342	M401OD07.5085-6.3A
90.0	105.0	6.3	90.0	343	M401OD07.5090-6.3A
95.0	110.0	6.3	95.0	345	M401OD07.5095-6.3A
100.0	115.0	6.3	100.0	347	M401OD07.5100-6.3A
105.0	120.0	6.3	105.0	348	M401OD07.5105-6.3A
110.0	125.0	6.3	110.0	350	M401OD07.5110-6.3A
115.0	130.0	6.3	115.0	351	M401OD07.5115-6.3A
120.0	135.0	6.3	120.0	353	M401OD07.5120-6.3A
125.0	140.0	6.3	125.0	354	M401OD07.5125-6.3A
130.0	145.0	6.3	130.0	356	M401OD07.5130-6.3A
135.0	150.0	6.3	135.0	358	M401OD07.5135-6.3A
140.0	155.0	6.3	140.0	359	M401OD07.5140-6.3A
150.0	165.0	6.3	150.0	362	M401OD07.5150-6.3A
160.0	175.0	6.3	160.0	363	M401OD07.5160-6.3A
170.0	185.0	6.3	170.0	365	M401OD07.5170-6.3A
180.0	195.0	6.3	180.0	366	M401OD07.5180-6.3A
190.0	205.0	6.3	190.0	368	M401OD07.5190-6.3A
200.0	220.6	8.1	200.0	446	M401OD10.3200-8.1A
210.0	230.6	8.1	210.0	446	M401OD10.3210-8.1A
220.0	240.6	8.1	220.0	447	M401OD10.3220-8.1A
230.0	250.6	8.1	230.0	448	M401OD10.3230-8.1A
240.0	260.6	8.1	240.0	449	M401OD10.3240-8.1A
250.0	270.6	8.1	250.0	450	M401OD10.3250-8.1A
260.0	280.6	8.1	260.0	450	M401OD10.3260-8.1A
270.0	294.2	8.1	270.0	452	M401OD12.1270-8.1A
280.0	304.2	8.1	280.0	453	M401OD12.1280-8.1A
290.0	314.2	8.1	290.0	454	M401OD12.1290-8.1A
300.0	324.2	8.1	300.0	455	M401OD12.1300-8.1A
320.0	344.2	8.1	320.0	458	M401OD12.1320-8.1A
350.0	374.2	8.1	350.0	458	M401OD12.1350-8.1A
360.0	384.2	8.1	360.0	462	M401OD12.1360-8.1A
400.0	424.2	8.1	400.0	367	M401OD12.1400-8.1A
420.0	444.2	8.1	420.0	463	M401OD12.1420-8.1A
450.0	474.2	8.1	450.0	466	M401OD12.1450-8.1A
460.0	484.2	8.1	460.0	468	M401OD12.1460-8.1A
480.0	504.2	8.1	480.0	469	M401OD12.1480-8.1A
500.0	524.2	8.1	500.0	469	M401OD12.1500-8.1A

\*If used with wear rings, refer to wear ring throat diameter, see Section 9.

For custom groove calculations, see Appendix C.

NOTE: For sizes larger than those shown in the table, please contact your local Parker Seal representative.

09/01/07



# Rod Seal V6 Profile

Catalog EPS 5370/USA

5



## V6 Profile, Cushion Seal

The V6 profile provides a check valve type action for use in cushioning pneumatic cylinders. The V6 profile seals against the cushioning piston or spud, allowing pneumatic pressure to build and cushion the cylinder's end stroke. Through a series of slots and pedestals the intake flow is then able to easily blow past the cushion seal to fill the cylinder. The installation of the cushion seal is very simple as it manually snaps into the groove recess. The V6 profile is available in proprietary Parker compounds formulated for low friction, extrusion resistance, and high temperature. The V6 profile can be used in a wide variety of NFPA cylinders and will provide excellent performance and long life.

## Technical Data

Standard Materials*	Temperature Range	Pressure Range†	Surface Speed
P4622A90	-65°F to 225°F (-54°C to 107°C)	250 psi (17 bar)	< 3 ft/s (1 m/s)
N4180A80	-40°F to 250°F (-40°C to 121°C)	250 psi (17 bar)	< 3 ft/s (1 m/s)
N4181A80	-40°F to 250°F (-40°C to 121°C)	250 psi (17 bar)	< 3 ft/s (1 m/s)
V4208A90	-5°F to 400°F (-21°C to 204°C)	250 psi (17 bar)	< 3 ft/s (1 m/s)

**\*Alternate Materials:** For applications that may require an alternate material, please contact your local Parker Seal representative.

**†Pressure Range** without wear rings (see Table 2-4, page 2-5).

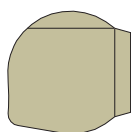

V6 Cross-Section

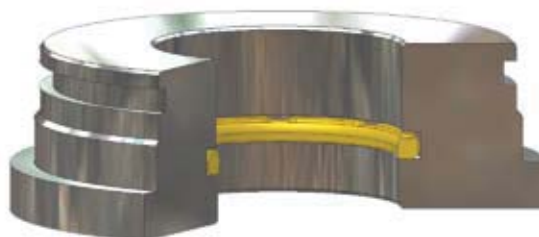

V6 Installed in Rod Gland

09/01/07

**Part Number Nomenclature — V6 Profile**

Table 5-35. V6 Profile — Inch

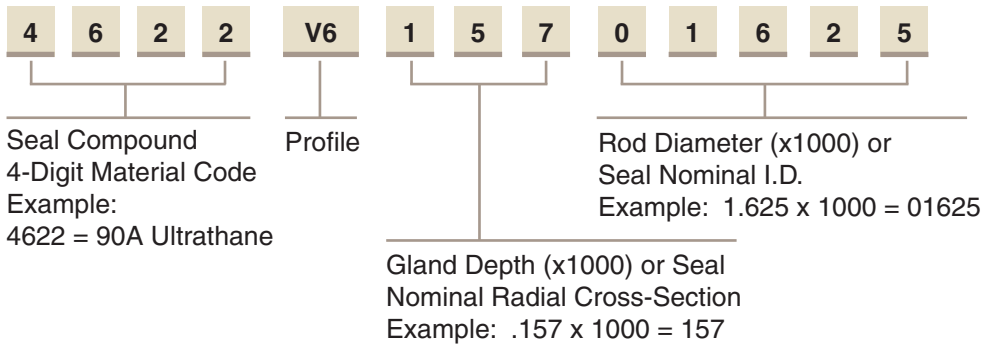

**Gland Dimensions — V6 Profile**

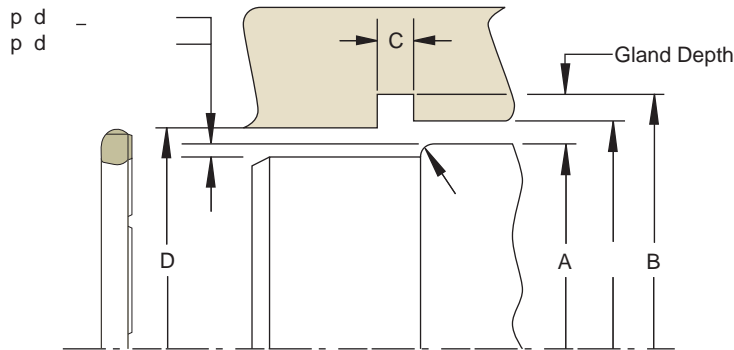

Please refer to Engineering Section 2, page 2-8 for surface finish and additional hardware considerations.



Table 5-36. V6 Gland Dimensions — Inch

Nominal Spud Diameter	A Spud Diameter	B Groove Diameter	C Groove Width	D Throat Diameter	E Throat Diameter	F Spud End Radius	Compound Codes (X = Standard Offering)			Part Number	
							4622	4180	4208	Compound Code	
3/8	0.368/0.370	0.685/0.689	0.181/0.197	0.390/0.393	0.449/0.453	0.118	X	X	X	XXXX	V615700375
5/8	0.617/0.620	0.935/0.940	0.181/0.197	0.640/0.644	0.699/0.703	0.118	X	X	X	XXXX	V615700625
3/4	0.742/0.745	1.060/1.065	0.181/0.197	0.765/0.769	0.824/0.828	0.118	X	X	X	XXXX	V615700750
7/8	0.877/0.880	1.195/1.201	0.181/0.197	0.900/0.905	0.959/0.964	0.118	X	X	X	XXXX	V615700875
1-3/16	1.179/1.184	1.578/1.585	0.228/0.244	1.208/1.215	1.263/1.270	0.157	X			XXXX	V619701187
1-1/4	1.249/1.253	1.568/1.574	0.181/0.197	1.273/1.279	1.332/1.338	0.118	X	X	X	XXXX	V615701250
1-5/8	1.620/1.624	1.939/1.945	0.181/0.197	1.644/1.650	1.703/1.709	0.118	X	X	X	XXXX	V615701625
1-5/8	1.616/1.622	2.016/2.023	0.228/0.244	1.646/1.653	1.701/1.709	0.157	X		X	XXXX	V619701625
2	1.992/1.997	2.391/2.398	0.228/0.244	2.021/2.028	2.076/2.083	0.157	X	X	X	XXXX	V619702000
2-1/4	2.242/2.247	2.562/2.569	0.181/0.197	2.267/2.274	2.326/2.333	0.118	X		X	XXXX	V615702250
2-3/4	2.735/2.740	3.291/3.300	0.323/0.339	2.764/2.771	2.858/2.865	0.197	X		X	XXXX	V627602750
4-1/4	4.219/4.225	4.776/4.786	0.323/0.339	4.249/4.258	4.343/4.352	0.197	X			XXXX	V627604250

NOTE: For sizes larger than those shown in the table, please contact your local Parker Seal representative.

## V6 Profile

### Part Number Nomenclature — V6 Profile

Table 5-37. V6 Profile — Metric

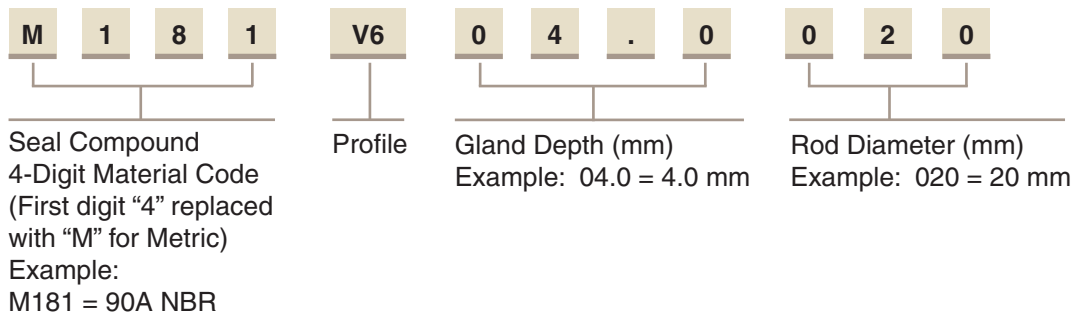

### Gland Dimensions — V6 Profile

1.5mm for Spud  $\varnothing \leq 20\text{mm}$   
2.0mm for Spud  $\varnothing > 20\text{mm}$

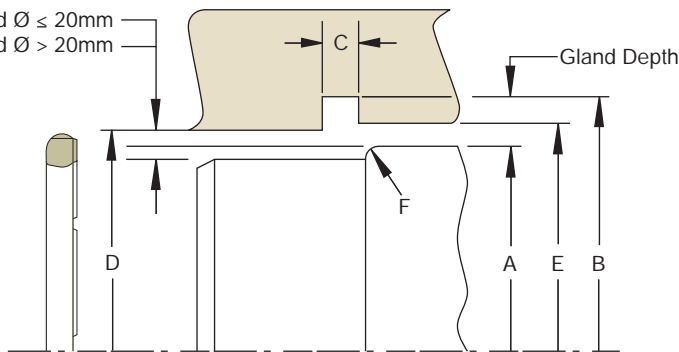

Please refer to Engineering Section 2, page 2-8 for surface finish and additional hardware considerations.

Table 5-38. V6 Gland Dimensions — Metric

Nominal Spud Diameter	A Spud Diameter	B Groove Diameter	C Groove Width	D Throat Diameter	E Throat Diameter	F Spud End Radius	Compound Codes (X = Standard Offering)		Part Number	
							M181	M208	Compound Code	
	h10	H11	+ .20/- .00	H11	H11					
For ISO tolerances refer to Appendix F.										
10.0	10.0	18.0	4,8	10.5	12.0	3.0	X	X	XXXX	V604.0010
14.0	14.0	22.0	4,8	14.5	16.0	3.0	X	X	XXXX	V604.0014
16.0	16.0	24.0	4,8	16.5	18.0	3.0	X		XXXX	V604.0016
20.0	20.0	28.0	4,8	20.5	22.0	3.0	X	X	XXXX	V604.0020
22.0	22.0	30.0	4,8	22.5	24.0	3.0	X		XXXX	V604.0022
30.0	30.0	40.0	6.0	30.6	32.0	4.0	X	X	XXXX	V605.0030
32.0	32.0	42.0	6.0	32.6	34.0	4.0	X	X	XXXX	V605.0032
38.0	38.0	48.0	6.0	38.6	40.0	4.0	X	X	XXXX	V605.0038
50.0	50.0	60.0	6.0	50.6	52.0	4.0	X	X	XXXX	V605.0050

NOTE: For sizes larger than those shown in the table, please contact your local Parker Seal representative.

# Rod Seal OR Profile

Catalog EPS 5370/USA



## OR Profile, Rotary PTFE Cap Seal

The Parker OR profile is a bi-directional rod seal for use in pneumatic and low to medium duty rotary or oscillating applications. The OR profile is a two piece design comprised of a standard size o-ring energizing a wear resistant PTFE cap. The OR profile offers long wear and low friction without stick-slip. This PTFE outer diameter is designed with a special interference with the o-ring to eliminate spinning between the o-ring and seal. Special grooves are designed into the PTFE inner diameter to provide lubrication and create a labyrinth effect for reduced leakage. The seal is commonly used in swivel joints, hose reels, and machine applications. Parker's OR profile will retrofit non-Parker seals of similar design.

The OR profile may be ordered without the energizer by omitting the energizer code. See part number nomenclature.

5

### Technical Data

Standard Materials* Cap	Temperature Range	Pressure Range†	Surface Speed
0205 15% fiberglass-, 5% MoS <sub>2</sub> -filled PTFE	-200°F to 575°F (-129°C to 302°C)	3000 psi (206 bar)	< 3.3 ft/s (1.0 m/sec)

### Energizer

A	70A Nitrile	-30°F to 250°F (-34°C to 121°C)
---	-------------	------------------------------------

\***Alternate Materials:** For applications that may require an alternate material, please see Section 3 for alternate PTFE (Table 3-4) and energizer (Table 3-5) materials.

†**Pressure Range** without wear rings (see Table 2-4, page 2-5).

**Minimum rotary shaft hardness = 60 Rc.**

**Note:** Small size cross sections feature single outer diameter grooves. Cross sections 305 and greater feature dual grooves.

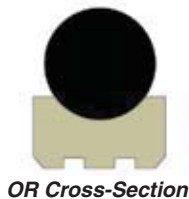

OR Cross-Section



OR installed on Rotary Shaft Gland

09/01/07



## OR Profile

### Part Number Nomenclature — OR Profile

Table 5-39. OR Profile — Inch

0	2	0	5	OR	1	4	7	0	2	0	0	0	-	1	2	6	A
Seal Compound 4-Digit Material Code Example: 0205 = 15% Fiberglass- 5% MoS <sub>2</sub> -filled PTFE				Profile	Gland Depth (x1000) Example: .147 x 1000 = 147				Bore Diameter (x1000) Example: 2.000 x 1000 = 02000				Groove Width (x1000) Example: .126 x 1000 = 126				Energizer Compound Code Example: A = 70A Nitrile Omit = No energizer See Table 3-5 on page 3-18.

Option:  
N = Notched walls  

5

### Gland Dimensions — OR Profile

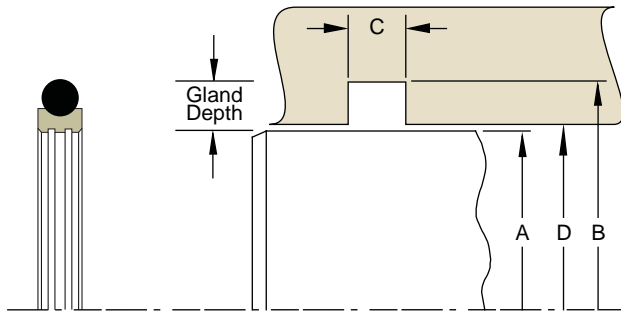

Please refer to Engineering Section 2, Page 2-8 for surface finish and additional hardware considerations.

Table 5-40. OR Gland Dimensions — Inch

A Rod Diameter	B Groove Diameter	C Groove Width	D Throat Diameter*	O-ring Dash Number	Part Number
<b>+.000/-0.001</b>	<b>+.001/-0.000</b>	<b>+.008/-0.000</b>	<b>+.002/-0.000</b>		
0.313	0.506	0.087	0.314	012	0205OR09700313-087A
0.375	0.568	0.087	0.376	013	0205OR09700375-087A
<b>+.000/-0.002</b>	<b>+.002/-0.000</b>	<b>+.008/-0.000</b>	<b>+.002/-0.000</b>		
0.438	0.631	0.087	0.439	014	0205OR09700438-087A
0.500	0.693	0.087	0.501	015	0205OR09700500-087A
0.563	0.756	0.087	0.564	016	0205OR09700563-087A
0.625	0.818	0.087	0.626	017	0205OR09700625-087A
0.688	0.881	0.087	0.689	018	0205OR09700688-087A
0.750	0.943	0.087	0.751	019	0205OR09700750-087A
0.813	1.006	0.087	0.814	020	0205OR09700813-087A
0.875	1.068	0.087	0.876	021	0205OR09700875-087A
0.938	1.131	0.087	0.939	022	0205OR09700938-087A
1.000	1.193	0.087	1.001	023	0205OR09701000-087A
1.125	1.318	0.087	1.126	025	0205OR09701125-087A
1.250	1.443	0.087	1.251	027	0205OR09701250-087A
1.375	1.568	0.087	1.376	028	0205OR09701375-087A

\*If used with wear rings, refer to wear ring throat diameter, see Section 9. For custom groove calculations, see Appendix C.

Table 5-40. OR Gland Dimensions — Inch (Continued)

A Rod Diameter	B Groove Diameter	C Groove Width	D Throat Diameter*	O-ring Dash Number	Part Number
<b>+ .000/- .002</b>	<b>+ .003/- .000</b>	<b>+ .008/- .000</b>	<b>+ .002/- .000</b>		
1.500	1.795	0.126	1.501	130	0205OR14801500-126A
1.625	1.920	0.126	1.626	132	0205OR14801625-126A
1.750	2.045	0.126	1.751	134	0205OR14801750-126A
1.875	2.170	0.126	1.876	135	0205OR14801875-126A
<b>+ .000/- .003</b>	<b>+ .003/- .000</b>	<b>+ .008/- .000</b>	<b>+ .002/- .000</b>		
2.000	2.295	0.126	2.001	137	0205OR14802000-126A
2.125	2.420	0.126	2.126	139	0205OR14802125-126A
2.250	2.545	0.126	2.251	141	0205OR14802250-126A
2.375	2.670	0.126	2.376	143	0205OR14802375-126A
2.500	2.795	0.126	2.501	145	0205OR14802500-126A
2.625	2.920	0.126	2.626	147	0205OR14802625-126A
2.750	3.045	0.126	2.751	149	0205OR14802750-126A
2.875	3.170	0.126	2.876	150	0205OR14802875-126A
<b>+ .000/- .003</b>	<b>+ .003/- .000</b>	<b>+ .008/- .000</b>	<b>+ .003/- .000</b>		
3.000	3.433	0.165	3.001	235	0205OR21703000-165A
3.125	3.558	0.165	3.126	236	0205OR21703125-165A
3.250	3.683	0.165	3.251	237	0205OR21703250-165A
3.375	3.808	0.165	3.376	238	0205OR21703375-165A
3.500	3.933	0.165	3.501	239	0205OR21703500-165A
3.625	4.058	0.165	3.626	240	0205OR21703625-165A
3.750	4.183	0.165	3.751	241	0205OR21703750-165A
3.875	4.308	0.165	3.876	242	0205OR21703875-165A
4.000	4.433	0.165	4.001	243	0205OR21704000-165A
4.125	4.558	0.165	4.126	244	0205OR21704125-165A
4.250	4.683	0.165	4.251	245	0205OR21704250-165A
<b>+ .000/- .003</b>	<b>+ .004/- .000</b>	<b>+ .008/- .000</b>	<b>+ .003/- .000</b>		
4.375	4.808	0.165	4.376	246	0205OR21704375-165A
4.500	4.933	0.165	4.501	247	0205OR21704500-165A
4.625	5.058	0.165	4.626	248	0205OR21704625-165A
<b>+ .000/- .004</b>	<b>+ .004/- .000</b>	<b>+ .008/- .000</b>	<b>+ .003/- .000</b>		
4.750	5.183	0.165	4.751	249	0205OR21704750-165A
4.875	5.308	0.165	4.876	250	0205OR21704875-165A
5.000	5.433	0.165	5.001	251	0205OR21705000-165A
5.125	5.558	0.165	5.126	252	0205OR21705125-165A
5.250	5.683	0.165	5.251	253	0205OR21705250-165A
5.375	5.808	0.165	5.376	254	0205OR21705375-165A
5.500	5.933	0.165	5.501	255	0205OR21705500-165A
5.625	6.058	0.165	5.626	256	0205OR21705625-165A
5.750	6.183	0.165	5.751	257	0205OR21705750-165A
5.875	6.308	0.165	5.876	258	0205OR21705875-165A
<b>+ .000/- .004</b>	<b>+ .004/- .000</b>	<b>+ .008/- .000</b>	<b>+ .004/- .000</b>		
6.000	6.610	0.248	6.002	362	0205OR30506000-248A
6.250	6.860	0.248	6.252	363	0205OR30506250-248A
6.500	7.110	0.248	6.502	364	0205OR30506500-248A
6.750	7.360	0.248	6.752	365	0205OR30506750-248A
7.000	7.610	0.248	7.002	365	0205OR30507000-248A

\*If used with wear rings, refer to wear ring throat diameter, see Section 9.  
For custom groove calculations, see Appendix C.

**OR Profile**

**Table 5-40. OR Gland Dimensions — Inch (Continued)**

A Rod Diameter	B Groove Diameter	C Groove Width	D Throat Diameter*	O-ring Dash Number	Part Number
<b>+ .000/- .005</b>	<b>+ .005/- .000</b>	<b>+ .008/- .000</b>	<b>+ .004/- .000</b>		
7.250	7.860	0.248	7.252	366	0205OR30507250-248A
7.500	8.110	0.248	7.502	367	0205OR30507500-248A
7.750	8.360	0.248	7.752	368	0205OR30507750-248A
8.000	8.610	0.248	8.002	369	0205OR30508000-248A
8.250	8.860	0.248	8.252	370	0205OR30508250-248A
8.500	9.110	0.248	8.502	371	0205OR30508500-248A
8.750	9.360	0.248	8.752	372	0205OR30508750-248A
9.000	9.610	0.248	9.002	373	0205OR30509000-248A
9.250	9.860	0.248	9.252	374	0205OR30509250-248A
9.500	10.110	0.248	9.502	375	0205OR30509500-248A
9.750	10.360	0.248	9.752	376	0205OR30509750-248A
10.000	10.610	0.248	10.002	377	0205OR30510000-248A
10.500	11.110	0.248	10.502	378	0205OR30510500-248A
11.000	11.610	0.248	11.002	379	0205OR30511000-248A
11.500	12.110	0.248	11.502	380	0205OR30511500-248A
<b>+ .000/- .006</b>	<b>+ .006/- .000</b>	<b>+ .008/- .000</b>	<b>+ .005/- .000</b>		
12.000	12.827	0.319	12.002	453	0205OR41412000-319A
12.500	13.327	0.319	12.502	454	0205OR41412500-319A
13.000	13.827	0.319	13.002	455	0205OR41413000-319A
13.500	14.327	0.319	13.502	456	0205OR41413500-319A
14.000	14.827	0.319	14.002	457	0205OR41414000-319A
14.500	15.327	0.319	14.502	458	0205OR41414500-319A
15.000	15.827	0.319	15.002	459	0205OR41415000-319A
15.500	16.327	0.319	15.502	460	0205OR41415500-319A
16.000	16.827	0.319	16.002	461	0205OR41416000-319A
16.500	17.327	0.319	16.502	462	0205OR41416500-319A
17.000	17.827	0.319	17.002	463	0205OR41417000-319A
17.500	18.327	0.319	17.502	464	0205OR41417500-319A
18.000	18.827	0.319	18.002	465	0205OR41418000-319A
18.500	19.327	0.319	18.502	466	0205OR41418500-319A
19.000	19.827	0.319	19.002	467	0205OR41419000-319A
19.500	20.327	0.319	19.502	468	0205OR41419500-319A
<b>+ .000/- .007</b>	<b>+ .007/- .000</b>	<b>+ .008/- .000</b>	<b>+ .005/- .000</b>		
20.000	20.827	0.319	20.002	469	0205OR41420000-319A

\*If used with wear rings, refer to wear ring throat diameter, see Section 9.

For custom groove calculations, see Appendix C.

NOTE: For sizes larger than those shown in the table, please contact your local Parker Seal representative.



**Part Number Nomenclature — OR Profile**

**Table 5-41. OR Profile — Metric**

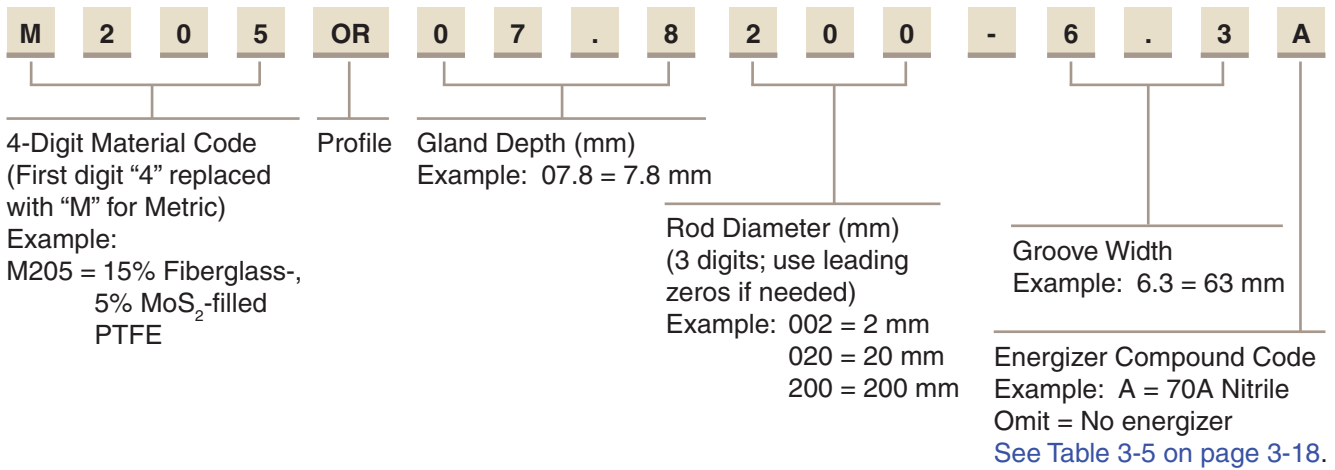

**Gland Dimensions — OR Profile**

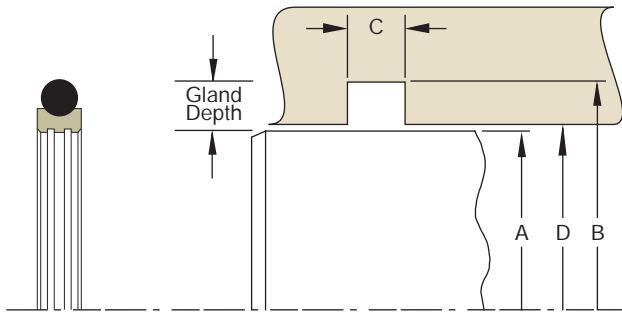

Please refer to Engineering Section 2, Page 2-8 for surface finish and additional hardware considerations.

**Table 5-42. OR Gland Dimensions — Metric**

A Rod Diameter	B Groove Diameter	C Groove Width	D Throat Diameter*	O-ring Dash Number	Part Number
f7	H9	+ .20/- .00	H8		
<b>For ISO tolerances refer to Appendix F.</b>					
6.0	10.9	2.2	6.0	011	M205OR02.5006-2.2A
8.0	12.9	2.2	8.0	012	M205OR02.5008-2.2A
10.0	14.9	2.2	10.0	013	M205OR02.5010-2.2A
12.0	16.9	2.2	12.0	014	M205OR02.5012-2.2A
14.0	18.9	2.2	14.0	016	M205OR02.5014-2.2A
15.0	19.9	2.2	15.0	016	M205OR02.5015-2.2A
16.0	20.9	2.2	16.0	017	M205OR02.5016-2.2A
18.0	22.9	2.2	18.0	018	M205OR02.5018-2.2A
20.0	27.5	3.2	20.0	118	M205OR03.8020-3.2A
22.0	29.5	3.2	22.0	119	M205OR03.8022-3.2A
25.0	32.5	3.2	25.0	121	M205OR03.8025-3.2A
28.0	35.5	3.2	28.0	123	M205OR03.8028-3.2A
30.0	37.5	3.2	30.0	124	M205OR03.8030-3.2A
32.0	39.5	3.2	32.0	126	M205OR03.8032-3.2A
35.0	42.5	3.2	35.0	127	M205OR03.8035-3.2A
36.0	43.5	3.2	36.0	128	M205OR03.8036-3.2A
40.0	51.0	4.2	40.0	224	M205OR05.5040-4.2A
42.0	53.0	4.2	42.0	224	M205OR05.5042-4.2A

\*If used with wear rings, refer to wear ring throat diameter, see Section 9.  
 For custom groove calculations, see Appendix C.



**OR Profile**

**Table 5-42. OR Gland Dimensions — Metric (continued)**

A Rod Diameter	B Groove Diameter	C Groove Width	D Throat Diameter*	O-ring Dash Number	Part Number
f7	H9	+.20/-00	H8		
For ISO tolerances refer to Appendix F.					
45.0	56.0	4.2	45.0	225	M205OR05.5045-4.2A
48.0	59.0	4.2	48.0	226	M205OR05.5048-4.2A
50.0	61.0	4.2	50.0	227	M205OR05.5050-4.2A
52.0	63.0	4.2	52.0	227	M205OR05.5052-4.2A
55.0	66.0	4.2	55.0	228	M205OR05.5055-4.2A
56.0	67.0	4.2	56.0	229	M205OR05.5056-4.2A
60.0	71.0	4.2	60.0	230	M205OR05.5060-4.2A
63.0	74.0	4.2	63.0	231	M205OR05.5063-4.2A
65.0	76.0	4.2	65.0	232	M205OR05.5065-4.2A
70.0	81.0	4.2	70.0	233	M205OR05.5070-4.2A
75.0	86.0	4.2	75.0	234	M205OR05.5075-4.2A
80.0	91.0	4.2	80.0	236	M205OR05.5080-4.2A
85.0	96.0	4.2	85.0	237	M205OR05.5085-4.2A
90.0	101.0	4.2	90.0	239	M205OR05.5090-4.2A
95.0	106.0	4.2	95.0	241	M205OR05.5095-4.2A
100.0	111.0	4.2	100.0	243	M205OR05.5100-4.2A
105.0	116.0	4.2	105.0	242	M205OR05.5105-4.2A
110.0	121.0	4.2	110.0	246	M205OR05.5110-4.2A
115.0	126.0	4.2	115.0	247	M205OR05.5115-4.2A
120.0	131.0	4.2	120.0	248	M205OR05.5120-4.2A
125.0	136.0	4.2	125.0	250	M205OR05.5125-4.2A
130.0	141.0	4.2	130.0	251	M205OR05.5130-4.2A
135.0	146.0	4.2	135.0	253	M205OR05.5135-4.2A
140.0	151.0	4.2	140.0	255	M205OR05.5140-4.2A
150.0	161.0	4.2	150.0	257	M205OR05.5150-4.2A
160.0	171.0	4.2	160.0	259	M205OR05.5160-4.2A
170.0	181.0	4.2	170.0	261	M205OR05.5170-4.2A
180.0	191.0	4.2	180.0	263	M205OR05.5180-4.2A
190.0	201.0	4.2	190.0	264	M205OR05.5190-4.2A
200.0	215.5	6.3	200.0	369	M205OR07.8200-6.3A
210.0	225.5	6.3	210.0	370	M205OR07.8210-6.3A
220.0	235.5	6.3	220.0	372	M205OR07.8220-6.3A
230.0	245.5	6.3	230.0	374	M205OR07.8230-6.3A
240.0	255.5	6.3	240.0	375	M205OR07.8240-6.3A
250.0	265.5	6.3	250.0	377	M205OR07.8250-6.3A
280.0	301.0	8.1	280.0	451	M205OR10.5280-8.1A
300.0	321.0	8.1	300.0	453	M205OR10.5300-8.1A
320.0	341.0	8.1	320.0	454	M205OR10.5320-8.1A
350.0	371.0	8.1	350.0	456	M205OR10.5350-8.1A
360.0	381.0	8.1	360.0	457	M205OR10.5360-8.1A
400.0	421.0	8.1	400.0	460	M205OR10.5400-8.1A
420.0	441.0	8.1	420.0	462	M205OR10.5420-8.1A
450.0	471.0	8.1	450.0	465	M205OR10.5450-8.1A
480.0	501.0	8.1	480.0	467	M205OR10.5480-8.1A
500.0	521.0	8.1	500.0	469	M205OR10.5500-8.1A
600.0	621.0	8.1	600.0	472	M205OR10.5600-8.1A

\*If used with wear rings, refer to wear ring throat diameter, see Section 9.

For custom groove calculations, see Appendix C.

NOTE: For sizes larger than those shown in the table, please contact your local Parker Seal representative.

